

English



Español



Italiano



Deutsch



Français



Nederlands



Polskie

### A series

Serie A • Serie A • A-Serie

Série A • A-serie • seria A

89

### BL series

Serie BL • Serie BL • BL-Serie

Série BL • BL-serie • seria BL

91

### BM series

Serie BM • Serie BM • BM-Serie

Série BM • BM-serie • seria BM

92

### C series

Serie C • Serie C • C-Serie

Série C • C-serie • seria C

93

### D series

Serie D • Serie D • D-Serie

Série D • D-serie • seria D

94

### F series

Serie F • Serie F • F-Serie

Série F • F-serie • seria F

95

### I series

Serie I • Serie I • I-Serie

Série I • I-serie • seria I

97

### M series

Serie M • Serie M • M-Serie

Série M • M-serie • seria M

98

### P series

Serie P • Serie P • P-Serie

Série P • P-serie • seria P

99

### Q series

Serie Q • Serie Q • Q-Serie

Série Q • Q-serie • seria Q

101



**BALL JOINTS**

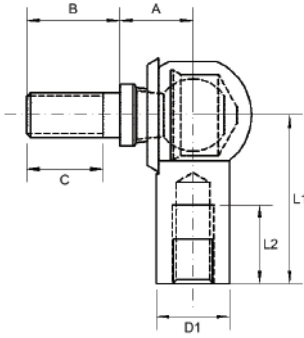

**A SERIES: AMG - AIG**

**Description:**

A-Series is our 4-piece standard range of nylon lined ball joints suitable for light to medium industrial/mechanical load applications requiring smooth action and good wear resistance. Available in both metric and imperial thread sizes. A-Series ball joints are also available without the ball stud allowing for assembly on to a pre-positioned stud. Please refer to compatible ball stud options in our miscellaneous product section. Neoprene gaiter helps resist dirt contamination, if gaiter is not required, please remove the letter G from the part number.

**Material Specifications:**

Body: Steel 230M07PB zinc plated and clear trivalent passivate.  
 Ball stud: Steel 230M07PB zinc plated and clear trivalent passivate.  
 Liner: Nylon 6 white. 300L Stainless Steel. Gaiter: Neoprene.

**Features**

- Metric & imperial thread sizes
- Ultra smooth action
- Can be assembled in situ
- Good wear resistance
- Lubricated

**Possible Applications**

- Industrial equipment
- Construction equipment
- Agricultural equipment
- Lawn & garden equipment

**Temperature Range**

-30°C to +120°C

**Specification**

ELV & RoHS compliant



**AMG-SERIES: LINER RETAINED (METRIC)**

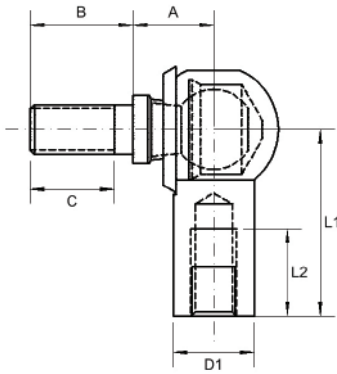

- Body:** Steel 230M07Pb, Zinc Plated and Clear Trivalent Passivate OR Zinc Plated and Yellow Hexavalent Passivate
- Liner:** Nylon 6
- Ball Stud:** Steel 230M07Pb, Zinc Plated and Clear Trivalent Passivate
- Dust Seal:** Neoprene Rubber
- Specification:** ELV and RoHS Compliant



Part No. Right Hand	Part No. Left Hand	Body Thread	Stud Thread	Ball Dia	L1	L2 Min	Stud A/F	A	B	C Min	D1
AMG6	AMG6LH	M6X1.00	M6X1.00	10	25.0	11.5	8	11.0	12.5	10.0	10
AMG6/2	AMG6/LH	M6X1.00	M8X1.25	10	25.0	11.5	8	11.0	12.5	10.0	10
AMG8	AMG8LH	M8X1.25	M8X1.25	13	30.0	14.0	11	13.0	16.5	13.5	13
AMG8/1	AMG8/1LH	M8X1.25	M8X1.25	13	41.0	25.0	11	13.0	16.5	13.5	13
AMG8/6	AMG8/6LH	M8X1.25	M8X1.25	13	41.0	25.0	11	13.0	20.0	13.5	13
AMG8/7	AMG8/7LH	M8X1.25	M8X1.25	13	30.0	14.0	11	13.0	20.0	17.5	13
AMG8/8	AMG8/8LH	M6X1.00	M8X1.25	13	30.0	14.0	11	13.0	16.5	13.5	13
AMG8/10	AMG8/10LH	M8X1.25	M8X1.25	13	30.0	14.0	11	13.0	18.5	15.5	13
AMG8/11	AMG8/11LH	M6X1.00	M8X1.25	13	51.0	25.0	11	13.0	16.5	13.5	13
AMG8/13	AMG8/13LH	M10X1.50	M8X1.25	13	30.0	15.0	11	13.0	16.5	13.5	13
AMG8/14	AMG8/14LH	M8X1.00	M8X1.25	13	25.0	12.0	11	13.0	16.5	13.5	13
AMG10	AMG10LH	M10X1.50	M10X1.50	16	35.0	15.5	13	16.0	20.0	15.0	16
AMG10/1	AMG10/1LH	M12X1.75	M10X1.50	16	45.0	25.5	13	16.0	20.0	15.0	16
AMG10/2	AMG10/2LH	M6X1.00	M10X1.50	16	30.0	10.5	13	14.5	19.0	11.1	16
AMG10/3	AMG10/3LH	M10X1.50	M10X1.50	16	35.0	15.5	13	16.0	25.0	20.0	16
AMG10/5	AMG10/5LH	M10X1.50	M10X1.50	16	35.0	15.5	13	16.0	20.0	15.0	16
AMG12	AMG12LH	M12X1.75	M12X1.75	16	45.0	25.5	13	16.0	20.0	17.0	16
AMG12/1	AMG12/1LH	M16X2.00	M12X1.75	16	45.0	30.0	13	16.0	20.0	17.0	16

**AIG-SERIES: LINER RETAINED (IMPERIAL)**

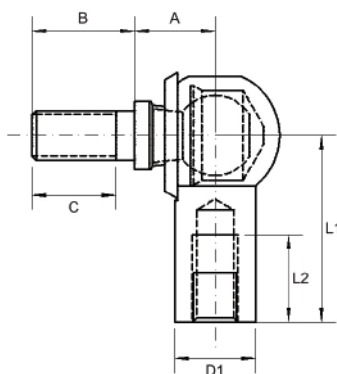

- Body:** Steel 230M07Pb, Zinc Plated and Clear Trivalent Passivate OR Zinc Plated and Yellow Hexavalent Passivate
- Liner:** Nylon 6
- Ball Stud:** Steel 230M07Pb, Zinc Plated and Clear Trivalent Passivate
- Dust Seal:** Neoprene Rubber
- Specification:** ELV and RoHS Compliant



Part No. Right Hand	Part No. Left Hand	Body Thread	Stud Thread	Ball Dia	L1	L2 Min	Stud A/F	A	B	C Min	D1
AIG312	AIG312LH	5/16 UNF	5/16 UNF	0.512	1.181	0.555	0.433	0.512	0.650	0.512	0.512
AIG312/1	AIG312/1LH	5/16 UNF	5/16 UNF	0.512	1.181	0.555	0.433	0.512	0.827	0.750	0.512

For stainless steel add 'SS' to part no. For example 'AMG6 SS'



BALL JOINTS



**BL-SERIES**

**Description:**

BL-Series is our 4-piece standard range of die cast zinc alloy ball joints suitable for medium industrial/mechanical load applications requiring smooth action and good wear resistance. The body is die cast around the ball giving an ultra smooth surface contact area, the ball stud is hardened and friction welded to the ball. The neoprene gaiter helps resist dirt contamination.

**Material Specifications:**

Body: Die cast zinc alloy. Ball: 100Cr6 bearing steel. Ball stud: Steel S35C hardened zinc plated and clear trivalent passivated. Gaiter: Neoprene.

**Features**

Metric thread sizes Ultra smooth action Strong & cost effective High pull out load axial & radial. Good wear resistance. Lubricated

**Possible Applications**

Industrial equipment Construction equipment Agricultural equipment Lawn & garden equipment

**Temperature Range**

-30°C to +120°C

**Specification**

ELV & RoHS compliant

**Interchange table**

Dunlop	IKO	THK	Alinabal	SKF	Asahi	Rose
BL (metric)	LHSA	BL-D	-	-	-	-

Note: Manufacturers part numbers are used for descriptive purposes only and may not be direct equivalent products.

**BL-SERIES: DIE CAST (METRIC)**

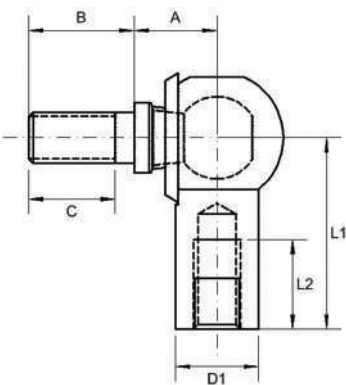

- Body:** Die Cast Zinc Alloy
- Ball:** Bearing Steel 100Cr6
- Ball Stud:** S35C, Hardened, Zinc Plated and Clear Trivalent Passivate
- Dust Seal:** Neoprene Rubber
- Specification:** ELV and RoHS Compliant



Part No. Right Hand	Part No. Left Hand	Body Thread	Stud Thread	Ball Dia	L1	L2 Min	Stud A/F	A	B	C Min	D1
BL6D	BL6DL	M6X1.00	M10X1.25	8	30	16	10	11.0	15.0	11.0	11
BL8D	BL8DL	M8X1.25	M8X1.25	8	36	19	12	14.0	17.0	12.0	14
BL10BD	BL10BDL	M10X1.50	M10X1.50	10	43	23	14	17.0	26.0	21.0	17
BL10D	BL10DL	M10X1.25	M10X1.25	13	43	23	14	17.0	20.0	15.0	17
BL12BD	BL12BDL	M12X1.75	M12X1.75	13	50	26	17	19.0	30.0	24.0	19
BL12D	BL12DL	M12X1.25	M12X1.25	13	50	26	17	19.0	23.0	17.0	19
BL14BD	BL14BDL	M14X2.00	M14X2.00	13	57	30	19	21.5	40.5	28.0	22
BL14D	BL14DL	M14X1.50	M14X1.50	13	57	30	19	21.5	34.5	22.0	22
BL16BD	BL16BDL	M16X2.00	M16X2.00	13	64	34	22	23.5	42.5	29.0	24
BL16D	BL16DL	M16X1.50	M16X1.50	13	64	34	22	23.5	36.5	23.0	24



BALL JOINTS



**BM-SERIES**

**Description:**

BM-Series is our 3-piece range of light weight nylon bodied ball joints, suitable for light industrial/mechanical load applications requiring smooth action and good wear resistance. BMG-Series ball joints are also available without the ball stud allowing for assembly on to a pre-positioned stud. Please refer to compatible ball stud options in our miscellaneous product section. BMG-Series ball joints can be moulded directly onto a linkage rod etc. Neoprene gaiter helps resist dirt contamination. If gaiter is not required please remove the letter G from the part number.

**Material Specifications:**

Body: Nylon 12 grey with graphite additive. Ball stud: Steel 230M07PB zinc plated and clear trivalent passivate. 303L Stainless Steel. Gaiter: Neoprene.

**Features**

Metric thread sizes  
Smooth action. Can be assembled in situ  
Good wear resistance  
Light weight. Economical  
Lubricated

**Possible Applications**

Light industrial equipment. Light agricultural equipment  
Lawn & garden equipment  
Engine controls

**Temperature Range**

-30°C to +120°C

**Specification**

ELV & RoHS compliant

**BMG-SERIES: LIGHT WEIGHT NYLON BODIED (METRIC)**

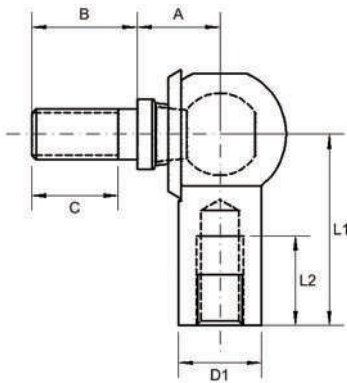

- Body:** Nylon 12 with Graphite Trace
- Ball Stud:** Steel 230M07Pb, Zinc Plated and Clear Trivalent Passivate
- Dust Seal:** Neoprene Rubber
- Specification:** ELV and RoHS Compliant



Part No. Right Hand	Part No. Left Hand	Body Thread	Stud Thread	Ball Dia	L1	L2 Min	Stud A/F	A	B	C Min	D1
BM5	BM5LH	M5X0.80	M5X0.80	8	20	12	7	9.0	10.2	8.6	10.0
BMG5	BMG5LH	M5X0.80	M5X0.80	8	20	12	7	9.0	10.2	8.6	10.0
BM5/6*	BM5/6LH*	M5X0.80	M5X0.80	8	20	12	7	9.0	10.2	8.6	10.0
BMG5/6*	BMG5/6LH*	M5X0.80	M5X0.80	8	20	12	7	9.0	10.2	8.6	10.0
BM6	BM6LH	M6X1.00	M6X1.00	10	24	14	8	11.0	12.5	10	12.0
BMG6	BMG6LH	M6X1.00	M6X1.00	10	24	14	8	11.0	12.5	10	12.0
BM8	BM8LH	M8X1.25	M8X1.25	13	30	17	11	13.0	16.5	13.5	15.0
BMG8	BMG8LH	M8X1.25	M8X1.25	13	30	17	11	13.0	16.5	13.5	15.0

BMG5/6\* Cross hole for locking pin.

For stainless steel add 'SS' to part no. For example 'BM5 SS'



BALL JOINTS



**C SERIES: CMG**

**Description:**

C-Series is our 5-piece range of spring retained and lockable ball joints suitable for medium industrial/mechanical load applications, inner ring retains the ball stud while the safety clip prevents the ball stud from being removed. CMG/1-Series ball joints are also available without the ball stud allowing for assembly on to a pre-positioned stud, please refer to compatible ball stud options in our miscellaneous product section.

**Material Specifications:**

Body: Steel 230M07PB zinc plated and clear trivalent passivate. Ball stud: Steel 212A42 hardened and zinc plated and clear trivalent passivate. Inner ring and safety clip: Spring steel to BS5216. Gaiter: Neoprene.

**Features**

Metric thread sizes  
Lubricated  
Can be assembled in situ  
Good wear resistance  
Medium duty  
Safety features

**Possible Applications**

Industrial equipment  
Construction equipment  
Agricultural equipment  
Lawn & garden equipment

**Temperature Range**

-30°C to +90°C

**Specification**

ELV & RoHS compliant

**CMG-SERIES: SPRING RETAINED (METRIC)**

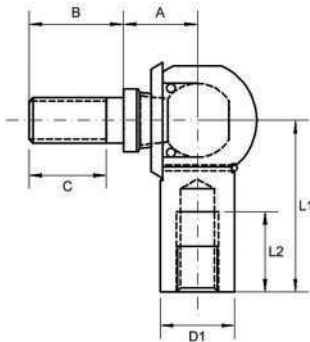

**Body:** Steel 230M07Pb, Zinc Plated and Clear Trivalent Passivate

**Ball Stud:** Steel 212A42, Hardened, Zinc Plated and Clear Trivalent Passivate

**Safety Clip:** Spring Steel

**Outer Clip:** Spring Steel

**Dust Seal:** Neoprene Rubber

**Specification:** ELV and RoHS Compliant



Part No. Right Hand	Part No. Left Hand	Body Thread	Stud Thread	Ball Dia	Body Flats	L1	L2 Min	Stud A/F	A	B	C Min	D1
CM5/1	CM5/1LH	M5X0.80	M5X0.80	8	7	22	10	7	9.0	10.2	7.7	8.0
CM6/1	CM6/1LH	M6X1.00	M6X1.00	10	9	25	11.5	8	11.0	12.5	10.0	10.0
CM8/1	CM8/1LH	M8X1.25	M8X1.25	13	11	30	14	11	13.0	16.5	14.0	13.0
CM10/1	CM10/1LH	M10X1.50	M10X1.50	16	13	35	15	13	16.0	20.0	17.5	16.0
CM12/1	CM12/1LH	M12x1.75	M12x1.75	16	14	35	15	13	16.0	20.0	17.5	16.0
CM14/1	CM14/1LH	M14X2.00	M14X2.00	19	19	45	21	16	20.0	28.0	22.0	22.0
CM16/1	CM16/1LH	M16X2.00	M16X2.00	19	-	45	21	16	20.0	28.0	22.0	22.0
CMG5/1	CMG5/1LH	M5X0.80	M5X0.80	8	7	22	10	7	9.0	10.2	7.7	8.0
CMG6/1	CMG6/1LH	M6X1.00	M6X1.00	10	9	25	11.5	8	11.0	12.5	10.0	10.0
CMG8/1	CMG8/1LH	M8X1.25	M8X1.25	13	11	30	14	11	13.0	16.5	14.0	13.0
CMG10/1	CMG10/1LH	M10X1.50	M10X1.50	16	13	35	15	13	16.0	20.0	17.5	16.0
CMG12/1	CMG12/1LH	M12x1.75	M12x1.75	16	14	35	15	13	16.0	20.0	17.5	16.0
CMG14/1	CMG14/1LH	M14X2.00	M14X2.00	19	19	45	21	16	20.0	28.0	22.0	22.0
CMG14C/1	CMG14C/1LH	M14X1.50	M14X1.50	19	19	45	21	16	20.0	28.0	22.0	22.0
CMG16/1	CMG16/1LH	M16X2.00	M16X2.00	19	-	45	21	16	20.0	28.0	22.0	22.0



**D-SERIES: DMG - DIG**

**Description:**

D-Series is our 3-piece range of swaged design ball joints, suitable for medium industrial/mechanical load applications. The swaging of the body produces a permanent assembly with the ball stud. Available in both metric and imperial thread sizes. Neoprene gaiter helps resist dirt contamination. If gaiter is not required please remove the letter G from the part number.

**Material Specifications:**

Body: Steel 230M07PB zinc plated and clear trivalent passivate. Ball stud: Steel 230M07PB hardened and zinc plated and clear trivalent passivate. Gaiter: Neoprene

**Features**

Metric & imperial thread  
Permanent assembly  
High pull out load  
Good wear resistance  
Lubricated

**Possible Applications**

Industrial equipment  
Construction equipment  
Agricultural equipment  
Lawn & garden equipment

**Temperature Range**

-30°C to +120°C

**Specification**

ELV & RoHS compliant

**Interchange table**

Dunlop	Tuthill	Dunlop	Tuthill
DMG (metric)	SPG-M	DIG (imperial)	SPG

*Note: Part numbers used for descriptive purposes only, may not be direct equivalent products.*

**DMG-SERIES: SWAGGED RETAINED (METRIC)**

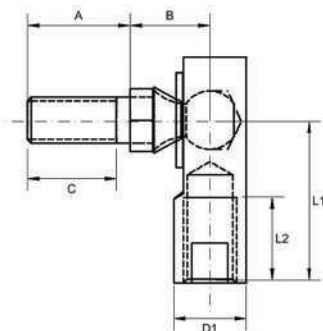

**Body:** Steel 230M07Pb, Zinc Plated and Clear Trivalent Passivate

**Ball Stud:** Steel 230M07Pb, Hardened, Zinc Plated and Clear Trivalent Passivate

**Dust Seal:** Neoprene Rubber

**Specification:** ELV and RoHS Compliant



Part No. Right Hand	Part No. Left Hand	Body Thread	Stud Thread	Ball Dia	L1	L2 Min	Stud A/F	A	B	C Min	D1
DMG6	DMG6LH	M6X1.00	M6X1.00	8.8	24.6	13.5	10	14.0	11.8	11.9	11.0
DMG6/1	DMG6/1LH	M6X1.00	M6X1.00	7.7	30.7	14.0	10	14.3	11.8	11.9	11.1
DMG6/2	DMG6/2LH	M6x1.00	M6X1.00	7.7	30.7	16.0	10	14.3	11.8	11.9	11.1
DMG8	DMG8LH	M8X1.25	M8X1.25	10.3	28.6	15.0	11	18.0	13.6	15.6	13.0
DMG8/1	DMG8/1LH	M8X1.25	M8X1.25	10.3	28.6	15.0	13	20.0	16.1	17.6	13.0
DMG10	DMG10LH	M10X1.50	M10X1.50	12.4	35.0	20.6	13	22.0	18.0	19.6	16.0

**DIG-SERIES: SWAGGED RETAINED (IMPERIAL)**

Part No. Right Hand	Part No. Left Hand	Body Thread	Stud Thread	Ball Dia	L1	L2 Min	Stud A/F	A	B	C Min	D1
DIG250	DIG250LH	1/4 UNF	1/4 UNF	0.347	0.969	0.531	0.375	0.562	0.466	0.468	0.437
DIG250/1	DIG250/1LH	1/4 BSF	M6x1.0	0.347	0.969	0.531	0.375	0.551	0.466	0.450	0.437
DIG250/2	DIG250/2LH	1/4 BSF	1/4 BSF	0.347	0.969	0.531	0.375	0.562	0.466	0.468	0.437
DIG312	DIG312LH	5/16 UNF	5/16 UNF	0.405	1.125	0.594	0.437	0.688	0.517	0.588	0.500
DIG312/1	DIG312/1LH	5/16 UNF	5/16 UNF	0.405	2.187	1.535	0.437	0.688	0.517	0.588	0.500
DIG375	DIG375LH	3/8 UNF	3/8 UNF	0.488	1.375	0.812	0.500	0.875	0.683	0.775	0.625
DIG375/1	DIG375/1LH	3/8 UNF	3/8 UNF	0.488	1.375	0.812	0.500	0.437	0.683	0.337	0.625
DIG375/2	DIG375/2LH	3/8 UNF	3/8 UNF	0.488	1.375	0.812	0.500	0.630	0.683	0.530	0.625
DIG375/3	DIG375/3LH	3/8 UNF	3/8 UNF	0.488	1.375	0.812	0.500	0.590	0.683	0.490	0.625



**BALL JOINTS**



**F SERIES: FMG - FIG**

**Description:**

F-Series is our 4-piece range of spring retained ball joints suitable for medium industrial/mechanical load applications. Available in both metric and imperial thread sizes. F-Series ball joints are ideal for severe wear conditions and are resistant to vibration and high shock loading. Neoprene gaiter helps resist dirt contamination. If gaiter is not required please remove the letter G from the part number.

**Material Specifications:**

Body: Steel 230M07PB ferritic nitrocarburised and zinc plated and clear trivalent passivate. Ball stud: Steel 230M07PB ferritic nitrocarburised and zinc plated and clear trivalent passivate. Inner ring: Hardened and tempered spring steel to BS5216. Gaiter: Neoprene.

**Features**

Metric & imperial thread sizes  
 High pull out load  
 High wear conditions  
 High shock loads  
 Resistant to vibration  
 Lubricated

**Possible Applications**

Industrial equipment  
 Construction equipment  
 Agricultural equipment  
 Lawn & garden equipment

**Temperature Range**

-30°C to +120°C

**Specification**

ELV & RoHS compliant

**Interchange table**

Dunlop	Tuthill	THK	Alinabal	SKF	Asahi	Rose
FMG (metric)	SRG-M	-	-	-	-	-
FIG (imperial)	SRG	-	-	-	-	-

*Note: Manufacturers part numbers are used for descriptive purposes only and may not be direct equivalent products.*





**FMG-SERIES: SPRING RETAINED (METRIC)**

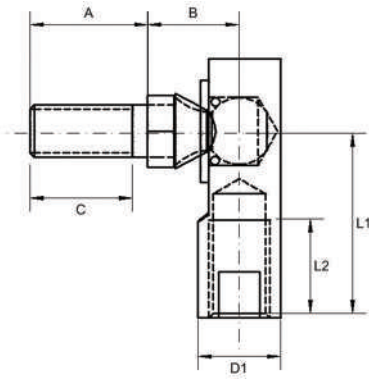

- Body:** Steel 230M07Pb, Zinc Plated and Clear Trivalent Passivate
- Ball Stud:** Steel 230M07Pb, Hardened, Zinc Plated and Clear Trivalent Passivate
- Dust Seal:** Neoprene Rubber
- Spring:** Spring Steel
- Specification:** ELV and RoHS Compliant



Part No. Right Hand	Part No. Left Hand	Body Thread	Stud Thread	Ball Dia	L1	L2 Min	Stud A/F	A	B	C Min	D1
FMG5	FMG5LH	M5X0.80	M5X0.80	7.75	24.6	12.7	10.00	14.30	11.90	12.0	11.11
FMG6	FMG6LH	M6X1.00	M6X1.00	7.75	24.6	12.7	10.00	14.30	11.90	12.0	11.11
FMG6/1	FMG6/1LH	M6X1.00	M6X1.00	7.75	19.2	7.3	10.00	14.30	11.90	12.0	11.11
FMG8	FMG8LH	M8X1.25	M8X1.25	8.74	28.4	14.2	13.00	17.45	13.50	15.0	12.70
FMG8/1	FMG8/1LH	M8X1.25	M8X1.25	8.74	41.0	25.0	13.00	17.45	13.50	15.0	12.70
FMG8/2	FMG8/2LH	M8X1.25	M8X1.25	8.74	28.4	14.2	13.00	11.50	13.50	9.0	12.70
FMG8/3	FMG8/3LH	M8X1.25	M6X1.00	8.74	28.4	14.2	10.00	12.70	13.50	10.0	12.70
FMG10	FMG10LH	M10X1.50	M10X1.50	10.59	35.0	19.0	13.00	22.23	17.45	20.0	15.88
FMG10/1	FMG10/1LH	M8X1.25	M10X1.50	10.59	35.0	19.0	13.00	22.23	17.45	20.0	15.88
FMG10/2	FMG10/2LH	M8X1.25	M10X1.50	10.59	35.0	19.0	13.00	12.00	17.45	9.5	15.88
FMG10/4	FMG10/4LH	M12X1.25	M10X1.50	10.59	35.0	19.0	15.88	18.00	17.45	15.5	15.88
FMG12	FMG12LH	M12X1.75	M12X1.75	14.10	49.2	25.4	17.00	28.60	22.20	26.0	19.05
FMG12/1	FMG12/1LH	M12X1.75	M10X1.50	14.10	49.2	25.4	17.00	28.60	22.20	26.0	19.05

**FIG-SERIES: SPRING RETAINED (IMPERIAL)**

Part No. Right Hand	Part No. Left Hand	Body Thread	Stud Thread	Ball Dia	L1	L2 Min	Stud A/F	A	B	C Min	D1
FIG250	FIG250LH	1/4 UNF	1/4 UNF	0.306	0.969	0.500	0.375	0.562	0.469	0.370	0.437
FIG312	FIG312LH	5/16 UNF	5/16 UNF	0.344	1.125	0.562	0.437	0.687	0.531	0.580	0.500
FIG312/1	FIG312/1LH	BLANK 0.312	5/16 UNF	0.344	1.125	0.562	0.437	0.687	0.531	0.580	0.500
FIG312/2	FIG312/2LH	5/16 UNF	5/16 UNF	0.344	1.120	0.562	0.437	0.687	0.531	0.580	0.500
FIG375	FIG375LH	3/8 UNF	3/8 UNF	0.416	1.375	0.750	0.500	0.875	0.687	0.770	0.625
FIG375/1	FIG375/1LH	3/8 UNF	3/8 UNF	0.416	1.772	1.181	0.500	0.787	0.866	0.680	0.625
FIG375/2	FIG375/2LH	3/8 BSF	3/8 UNF	0.416	1.375	0.750	0.500	0.787	0.866	0.680	0.625
FIG375/3	FIG375/3LH	3/8 UNF	3/8 UNF	0.416	1.375	0.750	0.500	0.620	0.688	0.520	0.625
FIG375/4	FIG375/4LH	7/16 UNF	3/8 UNF	0.416	1.375	0.750	0.500	0.620	0.688	0.520	0.625
FIG437/1	FIG437/1LH	7/16 UNEF	7/16 UNF	0.416	1.375	0.750	0.625	0.875	0.687	0.770	0.625
FIG500	FIG500LH	1/2 UNF	1/2 UNF	0.555	1.937	1.000	0.625	1.125	0.875	1.000	0.750



BALL JOINTS

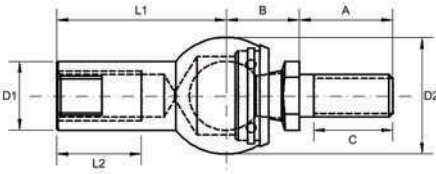

**I SERIES: IMG**

**Description:**

I-Series is our 5-piece range of inline nylon lined ball joints suitable for medium industrial/mechanical load applications. IMG has an inner ring that retains the ball stud and has no nylon liner. Available in both metric and imperial thread sizes.

**Material Specifications:**

Body: Steel 230M07PB case hardened and zinc plated and clear trivalent passivate. IL - Ball stud: Steel 230M07PB zinc plated and clear trivalent passivate. IMG - ball stud: Steel 212A42 induction hardened.

Liner: Nylon 6 white (No liner in IMG range). Inner ring and safety clip: Spring steel to BS5216. Gaiter: Neoprene

**Features**

Metric & imperial thread sizes. Ultra smooth action. High pull out loads. Good wear resistance. Push & pull applications Lubricated. Male to male option

**Possible Applications**

Industrial equipment  
Construction equipment  
Agricultural equipment  
Lawn & garden equipment

**Temperature Range**

-40°C to +80°C

**Specification**

ELV & RoHS compliant

**IMG-SERIES: IN-LINE FEMALE-MALE (METRIC)**

**Body:** Steel 230M07Pb, Zinc Plated and Clear Trivalent Passivate

**Ball Stud:** Steel 212A42, Hardened, Zinc Plated and Clear Trivalent Passivate

**Clip:** Spring Steel

**Dust Seal:** Neoprene Rubber

**Specification:** ELV and RoHS Compliant

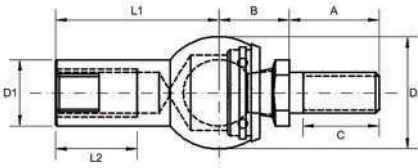

Part No. Right Hand	Part No. Left Hand	Body Thread	Stud Thread	Ball Dia	Body Flats	L1	L2 Min	Stud A/F	A	B	C Min	D1	D2
IM5	IM5LH	M5X0.80	M5X0.80	8	7	22	10.2	7	10.2	9.0	8.0	8.0	12.8
IMG5	IMG5LH	M5X0.80	M5X0.80	8	7	22	10.2	7	10.2	9.0	8.0	8.0	12.8
IM6	IM6LH	M6X1.00	M6X1.00	10	9	25	11.5	8	12.5	11.0	10.0	10.0	14.8
IMG6	IMG6LH	M6X1.00	M6X1.00	10	9	25	11.5	8	12.5	11.0	10.0	10.0	14.8
IM8	IM8LH	M8X1.25	M8X1.25	13	11	30	14.0	11	16.5	13.0	14.0	13.0	19.3
IMG8	IMG8LH	M8X1.25	M8X1.25	13	11	30	14.0	11	16.5	13.0	14.0	13.0	19.3
IM10	IM10LH	M10X1.50	M10X1.50	16	13	35	15.5	13	20.0	16.0	17.5	16.0	24.0
IMG10	IMG10LH	M10X1.50	M10X1.50	16	13	35	15.5	13	20.0	16.0	17.5	16.0	24.0
IM12	IM12LH	M12X1.75	M12X1.75	16	13	35	15.5	13	20.0	16.0	17.5	16.0	24.0
IMG12	IMG12LH	M12X1.75	M12X1.75	16	13	35	15.5	13	20.0	16.0	17.5	16.0	24.0
IM14	IM14LH	M14X1.50	M14X1.50	19	19	45	21.5	17	28.0	20.0	25.5	22.0	30.0
IMG14	IMG14LH	M14X1.50	M14X1.50	19	19	45	21.5	17	28.0	20.0	25.5	22.0	30.0
IM14/1	IM14/1LH	M14X2.00	M14X2.00	19	19	45	21.5	17	28.0	20.0	25.5	22.0	30.0
IMG14/1	IMG14/1LH	M14X2.00	M14X2.00	19	19	45	21.5	17	28.0	20.0	25.5	22.0	30.0

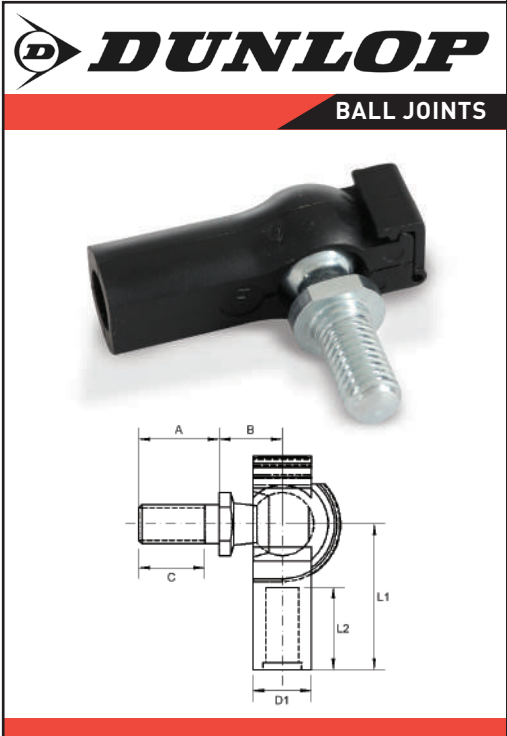

**M-SERIES**

**Description:**

M-Series is our 2-piece range of light weight nylon bodied lockable ball joints, suitable for light industrial/mechanical load applications requiring smooth action and good wear resistance. M-Series ball joints are also available without the ball stud, allowing for assembly on to a pre-positioned stud. Please refer to compatible ball stud options in our miscellaneous product section. M-Series ball joints have a unique locking clip incorporated into the one piece body, that when closed increases axial pull out and reduces backlash.

**Materials:**

Body: Nylon PA 6.6 black. Ball stud: Steel 230M07PB zinc plated and clear trivalent passivate.

**Features**

- Metric thread sizes
- Smooth action
- Can be assembled in situ
- Economical
- Light weight

**Possible Applications**

- Light industrial equipment
- Light agricultural equip.
- Lawn & garden equipment
- Engine controls

**Temperature Range**

-40°C to +80°C

**Specification**

ELV & RoHS compliant

**M-SERIES: SELF RETAINED (METRIC)**

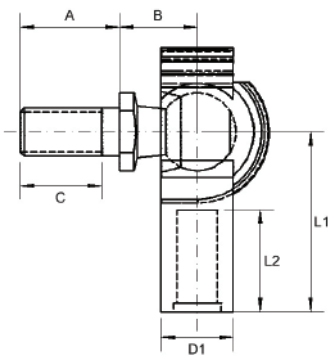

- Body:** PA 6.6
- Ball Stud:** Steel 230M07Pb, Zinc Plated and Clear Trivalent Passivate
- Specification:** ELV and RoHS Compliant



Part No. Right Hand	Body Thread	Stud Thread	Ball Dia	L1	L2 Min	Stud A/F	A	B	C Min	D1
M6008	M4X0.70	M4X0.70	6	17	10	5	6.5	8.5	5.5	8.0
M6010	M5X0.80	M5X0.80	8	22	12	7	10.2	9.0	8.6	9.5
M6012	M6X1.00	M6X1.00	10	25	14	8	12.5	11.0	10.0	12.0
M6014	M8X1.25	M8X1.25	13	30	17	11	16.5	13.0	13.5	15.0

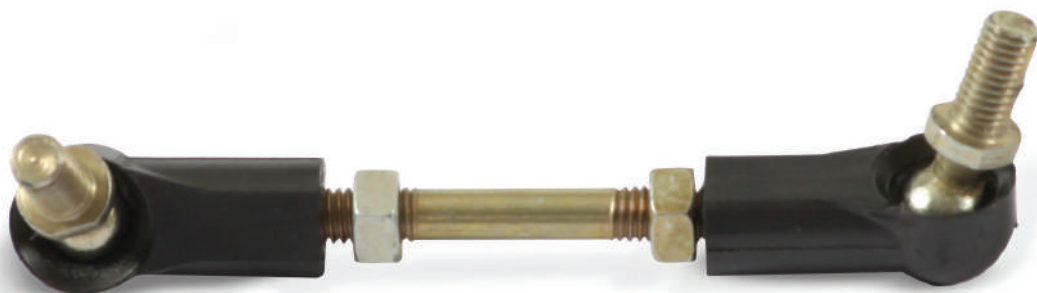



BALL JOINTS



**P SERIES: PM - PI**

**Description:**

P-Series is our 3-piece range of quick release ball joints, suitable for light industrial/mechanical load applications requiring good wear resistance. Available in both metric and imperial thread sizes. Easily disconnected or re-assembled during installation. P-Series ball joints are also available without the ball stud allowing for assembly on to a pre-positioned stud. Please refer to compatible ball stud options in our miscellaneous product section.

**Material Specifications:**

Body: Steel 230M07PB hardened and zinc plated and clear trivalent passivate  
Ball stud: Steel 230M07PB hardened and zinc plated and clear trivalent passivate  
Clip: CS70 carbon steel, hardened and tempered and geomet finish.

**Features**

Metric & imperial thread  
Easily disconnected or re-assembled during installation  
Can be assembled in situ  
Good wear resistance  
Lubricated. Light weight

**Possible Applications**

Light industrial  
Light construction  
Light agricultural  
Lawn & garden  
Automotive

**Temperature Range**

-30°C to +120°C

**Specification**

ELV & RoHS compliant

**Interchange table**

Dunlop	Tuthill	THK	Alinabal	SKF	Asahi	Rose
PM (metric)	SC-M	-	-	-	-	-
PI (imperial)	SC	-	-	-	-	-

*Note: Manufacturers part numbers are used for descriptive purposes only and may not be direct equivalent products.*

**PM-SERIES: CLIP RETAINED (METRIC)**

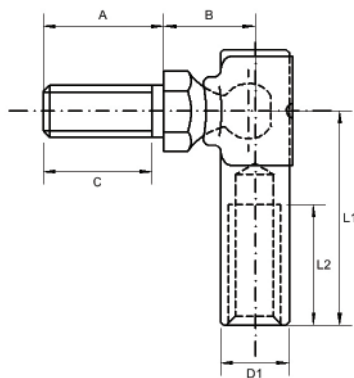

- Body:** Steel 230M07Pb, Zinc Plated and Clear Trivalent Passivate
- Ball Stud:** Steel 230M07Pb, Hardened, Zinc Plated and Clear Trivalent Passivate
- Clip:** CS 70 Carbon Steel
- Specification:** ELV and RoHS Compliant



Part No. Right Hand	Part No. Left Hand	Body Thread	Stud Thread	Ball Dia	L1	L2 Min	Stud A/F	A	B	C Min	D1
PM4	PM4LH	M4X0.70	M4X0.70	4.75	17	10	7	8.0	7.25	6.0	6.0
PM5	PM5LH	M5X0.80	M5X0.80	6.35	22	12	8	11.0	10.63	9.0	8.0
PM5/1	PM5/1LH	M6X1.00	M6X1.00	6.35	22	12	8	14.0	10.63	12.0	8.0
PM6	PM6LH	M6X1.00	M6X1.00	6.35	25	14	8	14.0	10.63	12.0	8.0
PM6/1	PM6/1LH	M6X1.00	M6X1.00	6.35	25	14	8	11.0	10.63	9.0	8.0
PM8	PM8LH	M8X1.25	M8X1.25	8.00	22	12	11	14.0	13.35	12.0	10.0

**PI-SERIES: CLIP RETAINED (IMPERIAL)**

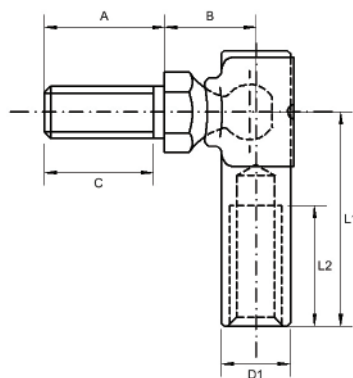

**Body:** Steel 230M07Pb, Zinc Plated and Clear Trivalent Passivate

**Ball Stud:** Steel 230M07Pb, Hardened, Zinc Plated and Clear Trivalent Passivate

**Clip:** CS 70 Carbon Steel

**Specification:** ELV and RoHS Compliant



Part No. Right Hand	Part No. Left Hand	Body Thread	Stud Thread	Ball Dia	L1	L2 Min	Stud A/F	A	B	C Min	D1
PI187	PI187LH	10-32 UNF	10-32 UNF	0.250	0.875	0.484	0.312	0.437	0.420	0.337	0.312
PI187/1	PI187/1LH	10-32 UNF	1/4 UNF	0.250	0.875	0.484	0.312	0.562	0.420	0.462	0.312
PI187/2	PI187/2LH	10-32 UNF	10-32 UNF	0.250	0.969	0.531	0.312	0.438	0.420	0.375	0.312
PI187/3	PI187/3LH	10-32 UNF	M6 X 1.00	0.250	0.875	0.484	0.312	0.551	0.420	0.489	0.312
PI187/4	PI187/4LH	0.080 dia	N/A	N/A	0.719	0.390	N/A	N/A	N/A	N/A	0.312
PI187/5	PI187/5LH	0.074 dia	N/A	N/A	0.875	0.250	N/A	N/A	N/A	N/A	0.312
PI250	PI250LH	1/4 UNF	1/4 UNF	0.250	0.970	0.531	0.312	0.562	0.420	0.460	0.312
PI250/1	PI250/1LH	1/4 UNF	10-32 UNF	0.250	0.970	0.531	0.312	0.437	0.420	0.330	0.312
PI250/2	PI250/2LH	0.228 dia	1/4 UNF	0.250	0.970	0.500	0.312	0.562	0.420	0.460	0.312
PI250/3	PI250/3LH	10-32 UNF	10-32 UNF	0.250	0.875	0.484	0.312	0.438	0.420	0.390	0.312
PI312	PI312LH	5/16 UNF	5/16 UNF	0.312	0.875	0.484	0.437	0.562	0.553	0.460	0.394





BALL JOINTS

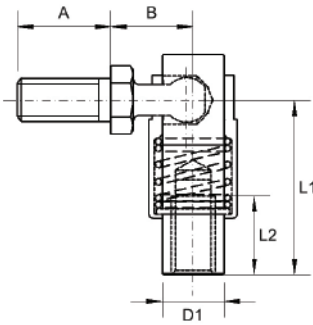

**Q SERIES: QM - QI**

**Description:**

Q-Series is our 4-piece range of quick release, spring loaded ball joints, suitable for medium industrial/mechanical load applications. Available in both metric and imperial thread sizes. Q-Series ball joints are also available without the ball stud allowing for assembly on to a pre-positioned stud. Please refer to compatible ball stud options in our miscellaneous product section. Q-Series ball joints are ideal for severe wear conditions and are resistant to vibration and high shock loading.

**Material Specifications:**

Body: Steel 230M07PB hardened and zinc plated and clear trivalent passivate.  
 Ball stud: Steel 230M07PB hardened and zinc plated and clear trivalent passivate.  
 Shield: Steel 230M07PB zinc plated and clear trivalent passivate  
 Spring: Stainless steel.

**Features**

- Metric & imperial thread
- High pull out load
- High wear conditions
- High shock loads
- Resistant to vibration
- Lubricated
- Knurl aids assembly

**Possible Applications**

- Industrial equipment
- Construction equipment
- Agricultural equipment
- Lawn & garden equipment

**Temperature Range**

-30°C to +120°C

**Specification**

ELV & RoHS compliant

**Interchange table**

Dunlop	Tuthill	THK	Alinabal	SKF	Asahi	Rose
QM (metric)	S-M	-	-	-	-	-
QI (imperial)	S	-	-	-	-	-

Note: Manufacturers part numbers are used for descriptive purposes only and may not be direct equivalent products.

**QM-SERIES: QUICK RELEASE (METRIC)**

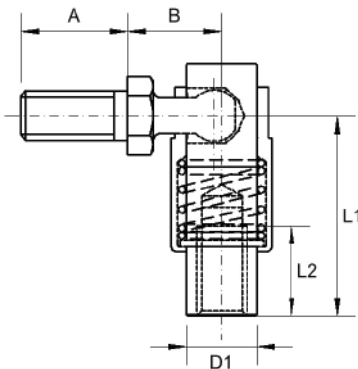

**Body:** Steel 230M07Pb, Zinc Plated and Clear Trivalent Passivate

**Ball Stud:** Steel 230M07Pb, Hardened, Zinc Plated and Clear Trivalent Passivate

**Shield:** Steel 230M07Pb, Zinc Plated and Clear Trivalent Passivate

**Spring:** 302S 26 Stainless Steel

**Specification:** ELV and RoHS Compliant

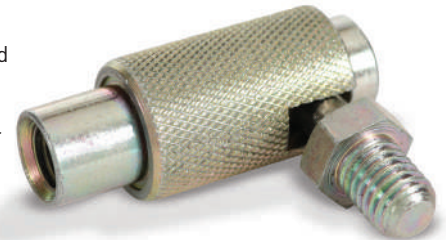

Part No. Right Hand	Part No. Left Hand	Body Thread	Stud Thread	Ball Dia	Length L1	Length L2	Stud A/F	A	B	C	D1
QM5	QM5LH	M5X0.80	M5X0.80	6.4	23.0	11.1	8	11.1	11.9	9.0	7.9
QM6	QM6LH	M6X1.00	M6X1.00	7.9	24.6	13.0	10	14.3	12.6	12.8	9.4
QM6/1	QM6/1LH	M6X1.00	M6X1.00	7.9	24.6	13.0	10	14.3	12.7	12.8	9.4
QM6/2	QM6/2LH	M6X1.00	M6X1.00	7.9	24.6	13.0	10	11.0	12.7	9.5	9.4
QM6/3	QM6/3LH	10-32 UNF	M6X1.00	7.9	24.6	13.0	10	14.3	12.7	12.8	9.4
QM6/4SS	QM6/4SSLH	M6X1.00	M6X1.00	7.9	24.6	13.0	10	14.3	12.7	12.8	9.4
QM8	QM8LH	M8X1.25	M8X1.25	8.6	31.7	14.3	11	17.5	14.0	15.5	11.1
QM8/1	QM8/1LH	M8X1.25	M6X1.00	8.6	31.7	14.3	11	17.5	14.0	15.5	11.1
QM8/2	QM8/2LH	M8X1.25	M8X1.25	8.6	31.7	14.3	11	11.0	14.0	9.0	11.1
QM8/3	QM8/3LH	M8X1.25	M8X1.25	8.6	31.7	14.3	11	10.0	15.2	8.0	11.1
QM8/4SS	QM8/4SSLH	M8X1.25	M6X1.00	8.6	31.7	14.3	11	17.5	15.2	15.5	11.1
QM10	QM10LH	M10X1.50	M10X1.50	10.7	39.7	27.0	13	22.2	19.8	20.0	14.1

**QI-SERIES: QUICK RELEASE (IMPERIAL)**

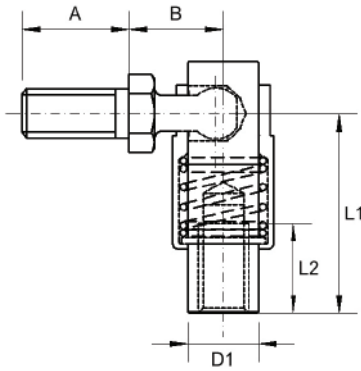

- Body:** Steel 230M07Pb, Zinc Plated and Clear Trivalent Passivate
- Ball Stud:** Steel 230M07Pb, Hardened, Zinc Plated and Clear Trivalent Passivate
- Shield:** Steel 230M07Pb, Zinc Plated and Clear Trivalent Passivate
- Spring:** 302S 26 Stainless Steel
- Specification:** ELV and RoHS Compliant

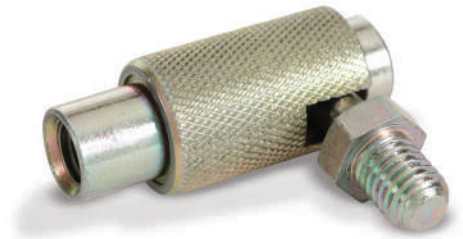

Part No. Right Hand	Part No. Left Hand	Body Thread	Stud Thread	Ball Dia	L1	L2 Min	Stud A/F	A	B	C	D1
QI187	QI187LH	10-32 UNF	10-32 UNF	0.250	0.906	0.437	0.312	0.437	0.468	0.330	0.310
QI187/2	QI1872LH	10-32 UNF	1/4" UNF	0.250	0.906	0.437	0.312	0.562	0.468	0.500	0.310
QI187/3	QI1873LH	10-32 UNF	M5 x 0.80	0.250	0.906	0.437	0.315	0.437	0.468	0.375	0.310
QI187/5	QI1875LH	10-32 UNF	M6 x 1.00	0.250	0.906	0.437	0.315	0.551	0.421	0.490	0.310
QI250	QI250LH	1/4" UNF	1/4" UNF	0.311	0.969	0.500	0.375	0.562	0.500	0.490	0.370
QI250/1	QI250/1LH	10-32 UNF	1/4" UNF	0.311	0.969	0.500	0.375	0.562	0.500	0.500	0.370
QI250/2	QI250/2LH	1/4" UNF	M6 x 1.00	0.311	0.969	0.500	0.394	0.562	0.500	0.500	0.370
QI250/4	QI250/4LH	1/4" BSF	1/4" BSF	0.311	0.969	0.500	0.375	0.562	0.500	0.500	0.370
QI250/5	QI250/5LH	1/4" UNF	5/16" UNF	0.311	0.969	0.500	0.375	0.882	0.449	0.820	0.370
QI250/6	QI250/6LH	1/4" UNF	1/4" UNF	0.311	0.969	0.500	0.375	0.875	0.449	0.812	0.370
QI312	QI312LH	5/16" UNF	5/16" UNF	0.339	1.250	0.562	0.437	0.687	0.594	0.580	0.439
QI312/1	QI312/1LH	5/16" BSF	5/16" BSF	0.339	1.250	0.562	0.437	0.687	0.594	0.625	0.439
QI312/2	QI312/2LH	1/4" UNF	5/16" UNF	0.339	1.250	0.562	0.437	0.882	0.594	0.820	0.439
QI312/3	QI312/3LH	5/16" UNF	5/16" UNF	0.339	1.250	0.562	0.437	0.882	0.594	0.820	0.439
QI312/4	QI312/4LH	10-32 UNF	5/16" UNF	0.339	1.250	0.562	0.437	0.882	0.594	0.820	0.439
QI375	QI375LH	3/8" UNF	3/8" UNF	0.421	1.562	1.062	0.500	0.875	0.719	0.770	0.556