



English



Español



Italiano



Deutsch



Français



Nederlands



Polskie

Engineering Data

219

Datos de ingeniería • Dati ingegneristici • Technische gegevens

Données d'ingénierie • Technische gegevens • Dane Inżynieria

Installation Details

220

Detalles de instalación • Dettagli di installazione • Details zur Installation

Détails d'installation • Installatiedetails • szczegóły dotyczące instalacji

Metric Taper Bushes

221

Casquillos cónicos métricos • Bussole coniche metriche

Metrische Kegel Büsche • Métriques moyeux amovibles

Metrische taper struiken • Metryczne tuleje stożkowe

Imperial Taper Bushes

223

Casquillos cónicos imperiales • Bussole coniche imperial

Imperial taper-Buchsen • Imperial moyeux amovibles

Imperial taper struiken • Cesarskie tuleje stożkowe



MINIMUM DIAMETERS OF TAPER BORED HUBS

The following table shows the recommended minimum diameter in mm for bespoke component hubs that are to be drilled, tapped and taper bored for use with Dunlop Taper bushes. All standard Dunlop Taper bushes are tested to ensure that they are capable of safely containing the radial and circumferential hub stresses generated by the wedging mechanism which makes Taper bushes the equivalent of a shrink-on fit.

TAPER BUSH	MINIMUM HUB DIAMETERS (mm) FOR VARIOUS MATERIALS			
	TENSILE STRENGTH N/mm ²			
	CAST IRON 180	CAST IRON 250	STEEL 420	STEEL 600
1008	62	54	51	47
1108	64	57	54	50
1210	104	86	78	69
1610	109	92	85	78
1615	90	81	77	73
2012	121	106	99	92
2517	130	119	113	108
3020	160	146	140	132
3030	144	136	132	127
3525	211	191	178	167
3535	191	176	168	160
4030	224	207	197	186
4040	209	195	188	180
4535	223	212	205	198
4545	215	205	200	194
5040	240	229	223	216
5050	233	223	219	213

AVERAGE SLIP TORQUES FOR TAPER BUSH FIXING

The following table shows average slip torque values in Nm for each basic Taper bush size with a variety of common metric bore diameters. The values assume that the assembly uses a Dunlop Taper bush fitted in accordance with the instructions supplied with every bush to a hub prepared to the Dunlop specification. With a key, the slip tendency transfers to the bush/hub interface at a greater torque value related to the ratio of bush outer dia to bore dia.

TAPER BUSH	BORE (mm)	AVERAGE SLIP TORQUE (Nm)
1008	12	29
	19	59
	24	66
1108	12	28
	19	49
	28	79
1210	16	82
	24	142
	32	210
1610 1615	19	98
	24	135
	42	265
2012	24	320
	42	340
	50	420
2517	24	220
	42	430
	60	670

TAPER BUSH	BORE (mm)	AVERAGE SLIP TORQUE (Nm)
3020 3030	38	520
	55	890
	75	1300
3525* 3535	42	1000
	75	2150
	100	3075
4030* 4040	48	1700
	75	3150
	115	5150
4535 4545	55	2500
	100	5500
	125	6625
5040 5050	75	3950
	100	5650
	125	7370

Large bores marked* are only available in bush sizes marked*

TO INSTALL

- Remove the protective coating from the bore and outside of bush and bore of hub. After ensuring that the mating tapered surfaces are completely clean and free from oil or dirt, insert bush in hub so that holes line up.
- Sparingly oil thread and point of grub screws, or thread and under head of cap screws. Place screws loosely in holes threaded in hub, shown thus  in diagram.
- If a key is to be fitted place it in the shaft keyway before fitting the bush. It is essential that it is a parallel key and side fitting only and has TOP CLEARANCE.
- Clean shaft and fit hub to shaft as one unit and locate in position desired, remembering that bush

will nip the shaft first and then the hub will be slightly drawn on to the brush.

- Using a hexagon wrench tighten screws gradually and alternately to torque shown in table below.
- Hammer against large-end of bush, using a block or sleeve to prevent damage. (This will ensure that the bush is seated squarely in the bore). Screws will now turn a little more. Repeat this alternate hammering and screw tightening once or twice to achieve maximum grip on the shaft.
- After drive has been running under load for a short time stop and check tightness of screws.
- Fill empty holes with grease to exclude dirt.

TO REMOVE

- Slacken all screws by several turns, remove one or two according to number of removal holes shown thus  in diagram. Insert screws into removal holes after oiling thread and under head of cap screws.
- Tighten screws alternately until bush is loosened in hub and assembly is free on the shaft.
- Remove assembly from shaft.

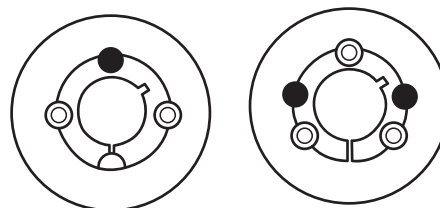

Removal holes 

BUSH SIZE		1008	1108	1210	1610	1615	2012	2517	3020	3030	3525	3535	4030	4040	4535	4545	5040	5050
Screw tightening torque (Nm)		5.6	5.6	20	20	20	30	50	90	90	115	115	170	170	190	190	270	270
QTY		2	2	2	2	2	2	2	2	2	3	3	3	3	3	3	3	3
Screw Details	Size (BSW)	1/4"	1/4"	3/8"	3/8"	3/8"	7/16"	1/2"	5/8"	5/8"	1/2"	1/2"	5/8"	5/8"	3/4"	3/4"	7/8"	7/8"
	Hex, Socket size (mm)	3	3	5	5	5	6	6	8	8	10	10	12	12	14	14	14	14
Large end dia. (mm)		35.0	38.0	47.5	57.0	57.0	70.0	85.5	108	108	127	127	146	146	162	162	178	178
Bush length (mm)		22.3	22.3	25.4	25.4	38.1	31.8	44.5	50.8	76.2	63.5	89.0	76.2	102	89.0	114	102	127
Approx mass (kg)		0.1	0.1	0.2	0.3	0.5	0.7	1.5	2.7	3.6	3.8	5.0	5.6	7.7	7.5	10.0	11.1	14.0



TAPER BUSHES

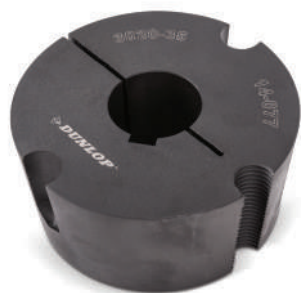

TAPER BUSHES

Description

Dunlop Taper Bushes are the most convenient and cost effective method of fixing components to a mating shaft without using any special tools. Taper Bushes are pre-machined with the required bore & keyway size and are supplied complete with locking set screws, thus making savings in time and cost on any machining process. They are available with both metric or imperial bore and keyway size options.

Taper Bushes are designed for use with V-Pulleys, Chain Sprockets, Micro V-Pulleys, Timing Belt Pulleys, Couplings, Weld-On & Bolt-On Hubs. Part numbers are identified by a 4 digit number (e.g. 1610) which represents the taper bush series followed by the bore size (e.g. 28mm) for example 1610x28mm.

METRIC BORES AND KEYWAYS

BORE DIA.	KEYWAY		SHALLOW KEYWAY DEPTH	TAPER BUSH PART NUMBER								
	WIDTH	DEPTH		1008	1108	1210	1610	1615	2012	2517	3020	3030
9	3	1.4	-	*	*							
10	3	1.4	-	*	*							
11	4	1.8	-	*	*	*						
12	4	1.8	-	*	*	*						
14	5	2.3	-	*	*	*	*	*	*			
15	5	2.3	-	*	*	*	*	*	*			
16	5	2.3	-	*	*	*	*	*	*	*		
18	6	2.8	-	*	*	*	*	*	*	*		
19	6	2.8	-	*	*	*	*	*	*	*		
20	6	2.8	-	*	*	*	*	*	*	*		
22	6	2.8	-	*	*	*	*	*	*	*		
24	8	3.3	1.3	*	*	*	*	*	*	*		
25	8	3.3	1.3	*	*	*	*	*	*	*	*	
28	8	3.3	1.3		*	*	*	*	*	*	*	
30	8	3.3	-			*	*	*	*	*	*	
32	10	3.3	-			*	*	*	*	*	*	
35	10	3.3	-				*	*	*	*	*	*
38	10	3.3	-				*	*	*	*	*	*
40	12	3.3	-				*	*	*	*	*	*
42	12	3.3	2.2				*	*	*	*	*	*
45	14	3.8	-						*	*	*	*
48	14	3.8	-						*	*	*	*
50	14	3.8	-						*	*	*	*
55	16	4.3	-							*	*	*
60	18	4.4	-							*	*	*
65	18	4.4	-								*	*
70	20	4.9	-								*	*
75	20	4.9	-								*	*

METRIC BORES AND KEYWAYS

BORE DIA.	KEYWAY		SHALLOW KEYWAY DEPTH	TAPER BUSH PART NUMBER							
	WIDTH	DEPTH		3525	3535	4030	4040	4535	4545	5040	5050
35	10	3.3	-	*	*						
38	10	3.3	-	*	*						
40	12	3.3	-	*	*	*	*				
42	12	3.3	-	*	*	*	*				
45	14	3.8	-	*	*	*	*				
48	14	3.8	-	*	*	*	*				
50	14	3.8	-	*	*	*	*				
55	16	4.3	-	*	*	*	*	*	*		
60	18	4.4	-	*	*	*	*	*	*		
65	18	4.4	-	*	*	*	*	*	*		
70	20	4.9	-	*	*	*	*	*	*	*	*
75	20	4.9	-	*	*	*	*	*	*	*	*
80	22	5.4	-	*	*	*	*	*	*	*	*
85	22	5.4	-	*	*	*	*	*	*	*	*
90	25	5.4	-	*	*	*	*	*	*	*	*
95	25	5.4	-	*		*	*	*	*	*	*
100	28	6.4	4.4	*		*	*	*	*	*	*
105	28	6.4	-			*		*	*	*	*
110	28	6.4	-			*		*	*	*	*
115	32	7.4	5.4			*		*		*	*
120	32	7.4	-					*		*	*
125	32	7.4	-					*		*	*



INCH BORES AND KEYWAYS

BORE DIA.	KEYWAY		SHALLOW KEYWAY DEPTH	TAPER BUSH PART NUMBER								
	WIDTH	DEPTH		1008	1108	1210	1610	1615	2012	2517	3020	3030
0.375	0.125	0.06	-	*	*							
0.500	0.125	0.06	-	*	*		*	*				
0.625	0.187	0.09	-	*	*	*	*	*				
0.750	0.187	0.09	-	*	*	*	*	*	*	*		
0.875	0.250	0.12	-	*	*	*	*	*	*	*		
1.000	0.250	0.12	0.052	*	*	*	*	*	*	*		
1.125	0.312	0.11	0.064		*	*	*	*	*	*		
1.250	0.312	0.11	-			*	*	*	*	*	*	*
1.375	0.375	0.11	-				*	*	*	*	*	*
1.500	0.375	0.11	-				*	*	*	*	*	*
1.625	0.437	0.13	0.103				*	*	*	*	*	*
1.750	0.437	0.13	-						*	*	*	*
1.875	0.500	0.13	-						*	*	*	*
2.000	0.500	0.13	-						*	*	*	*
2.125	0.625	0.18	-							*	*	*
2.250	0.625	0.18	-							*	*	*
2.375	0.625	0.18	-							*	*	*
2.500	0.625	0.18	-							*	*	*
2.625	0.750	0.21	-								*	*
2.750	0.750	0.21	-								*	*
2.875	0.750	0.21	-								*	*
3.000	0.750	0.21	-								*	*

METRIC BORES AND KEYWAYS

BORE DIA.	KEYWAY		SHALLOW KEYWAY DEPTH	TAPER BUSH PART NUMBER								
	WIDTH	DEPTH		3525	3535	4030	4040	4535	4545	5040	5050	
1.500	0.375	0.11	-	*	*							
1.625	0.437	0.13	-	*	*							
1.750	0.437	0.13	-	*	*	*	*					
1.875	0.500	0.13	-	*	*	*	*					
2.000	0.500	0.13	-	*	*	*	*					
2.125	0.625	0.18	-	*	*	*	*					
2.250	0.625	0.18	-	*	*	*	*	*	*			
2.375	0.625	0.18	-	*	*	*	*	*	*			
2.500	0.750	0.18	-	*	*	*	*	*	*			
2.625	0.750	0.21	-	*	*	*	*	*	*			
2.750	0.750	0.21	-	*	*	*	*	*	*	*	*	*
2.875	0.750	0.21	-	*	*	*	*	*	*	*	*	*
3.000	0.875	0.21	-	*	*	*	*	*	*	*	*	*
3.125	0.875	0.26	-	*	*	*	*	*	*	*	*	*
3.250	0.875	0.26	-	*	*	*	*	*	*	*	*	*
3.375	0.875	0.26	-	*	*	*	*	*	*	*	*	*
3.500	1.000	0.26	-	*	*	*	*	*	*	*	*	*
3.750	1.000	0.32	0.245	*		*	*	*	*	*	*	*
4.000	1.250	0.32	0.155	*		*	*	*	*	*	*	*
4.250	1.250	0.37	-			*		*	*	*	*	*
4.500	1.250	0.37	0.255			*		*	*	*	*	*
4.750	1.250	0.37	-					*		*	*	*
5.000	1.250	0.37	0.258					*		*	*	*

English

Español

Italiano

Deutsch

Français

Nederlands

Polskie
Cross Reference Table
224

Tabla de referencia de Cross • Tabella di riferimento trasversale
 Kreuz Referenztafel • Table de référence croisée • Kruis referentietabel
 Tabele kompatybilności

Engineering Data
225

Datos de ingeniería • Dati ingegneristici • Technische gegevens
 Données d'ingénierie • Technische gegevens • Dane Inżynieria

Locking Devices
227

Dispositivos de cierre cónicos • Dispositivi di bloccaggio bussola conica
 Kegel Busch Verriegelungen • Dispositifs de verrouillage conique bush
 Taper bush vergrendeling apparaten • stożek krzak urządzenia blokujące

Interchange table

DUNLOP	FENNER DRIVES B-LOC	BONFIGLIOLI BONFIX	CHIARAVALLI	TRANSDEV DRIVELOCK	CHALLENGE EASTLOCK	FENNER/ERIKS FENLOCK	POGGI POGGILOCK	RINGFEDER	RINGSPAN	TOLLOK
DLK110	B-800	1000	RCK 80	80	02	FLK110	CAL-B	RFN 7110	RLK110	TLK110
DLK130	-	4000	RCK 70	70	04	FLK130	CAL-D	TI 9013.A	RLK130	TLK130
DLK131	B-103	4500	RCK 71	71	06	FLK131	CAL-E	TI 9013.B	RLK131	TLK131
DLK132	-	4100	RCK 13	13	05	FLK132	CAL-DS	RFN 7013.0	RLK132	TLK132
DLK133	B-106	4600	RCK 16	16	07	FLK106/133	CAL-ES	RFN 7013.1	RLK133	TLK106/133
DLK134	-	4900	RCK 15	15	15	FLK134	-	-	RLK134	TLK134
DLK200	B-400	2000	RCK 40	40	01	FLK200	CAL-A	RFN 7012	RLK200	TLK 200
DLK300	B-500	3000	RCK 50	50	03	FLK300	CAL-C	RFN 8006	RLK300	TLK300
DLK450	B-112	9500	RCK 11	11	19	FLK450	CAL-F	RFN 7015.0	RLK450	TLK450
DLK603	SD-10	8000	RCK 19	19	14	FLK603	CAL-SD	RFN 4071	RLK603	TLK603

TECHNICAL INFORMATION

The functioning principle of the articles presented is based on radial deformation of the items, made up of a truncated cone section: the tightening torque applied to the connecting screws causes an axial movement of the parts in contact with each other and in function of the inverse cone shape and the longitudinal cuts made on them provokes an increase in the diameter (of the external ring) and a reduction of the diameter (of the internal ring).

This changes allows (by virtue of the specific pressure between the bodies in contact) transmission of the torque between the shaft and the part connected to it (gear, timing belt pulley, V-Belt pulley or other specific parts).

- The advantages of the system block are as follows:
- Elimination of play between the shaft and the part driven.
- Uniform distribution of the load over the entire diameter
- Facility of synchronisation between the various possible parts connected as a set
- Reduction of the diameter (of project) of the drive shaft
- Increase of the resistant section of the drive shaft
- Reduction of the procurement times for machine assembly
- Maintenance facilitated with no need to stop the machine
- Availability of spare parts by main sub-suppliers of technical equipment

	DLK132	DLK133	DLK134	DLK110	DLK130	DLK131	DLK450	DLK200	DLK300	DLK603
SELF CENTERING	●	●	●	●	●	●	●			
NOT SELF CENTERING								●	●	●
MINIMUM RADIAL DIMENSIONS				●					●	
RAPID MAINTENANCE AND ASSEMBLY	●	●	●	●	●	●		●	●	●
MEDIUM TO LOW TORQUE									●	
MEDIUM TO HIGH TORQUE	●	●						●		●
HIGH TORQUE			●		●	●	●			
SELF LOCKING	●	●	●	●	●	●	●			
NON SELF LOCKING								●	●	●

Duty Factor (s)	LOAD TYPE		
	Constant	Intermittent	Alternating
Electric Motor	1 - 1.2	1.2 - 1.5	1.5 - 2
Combustion Engine	1.2 - 1.5	1.5 - 2	2 - 3

TECHNICAL SPECIFICATION

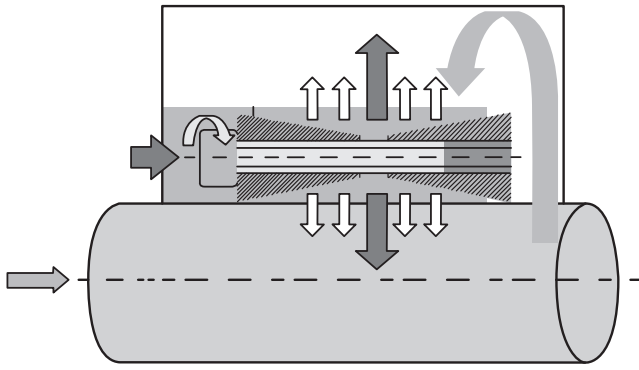

- Pm** Pressure of locking set on hub
- Pa** Pressure of locking set on shaft
- Ta** Axial force transmissible
- Tv** Screw tightening torque
- Tm** Axial force exerted
- Mt** Transmissible torque of locking set
- Pt** Radial force (pressure)

$$P_t \text{ hub} = \pi \cdot D \cdot H_2 \cdot P_m$$

$$P_t \text{ shaft} = \pi \cdot d \cdot H_2 \cdot P_a$$

$$P_t = P_t \cdot \mu \cdot d/2$$

$$T_a = 2 \cdot M_t \cdot s$$

$$P_t \text{ shaft} = P_t \text{ hub}$$

μ = coefficient of friction (0.13) for lubricated locking set (dry 0.15)

s = Duty Factor

Screws UNI 5931 DIN 6912-7984	Pitch (mm)	Tightening torque Tv with class 12.9 screws NM (UNI 3740-9)
M6	1.00	17.5
M8	1.25	42.0
M10	1.50	85.0
M12	1.75	145.0
M14	2.00	235.0
M16	2.00	360.0
M18	2.50	485.0
M20	2.50	705.0
M22	2.50	960.0
M24	3.00	1220.0
M30	3.00	2400.0

Tolerance and degree of roughness of surfaces.

Shaft:
Tolerance h8
roughness Rz <= 16 μm

Hub:
Tolerance H8
roughness Rz <= 16 μm



LOCKING DEVICES



LOCKING DEVICES

Description

Taper Bush Locking devices are precision made to provide a wide, versatile range of key less shaft/hub fixing assemblies. Their design is such they can be fitted to any mating component that has a parallel bore.

They offer simple installation, resistance to alternating torques, increased shaft strength, zero backlash, actual and angular adjustment therefore creating high torque transmission capacity.

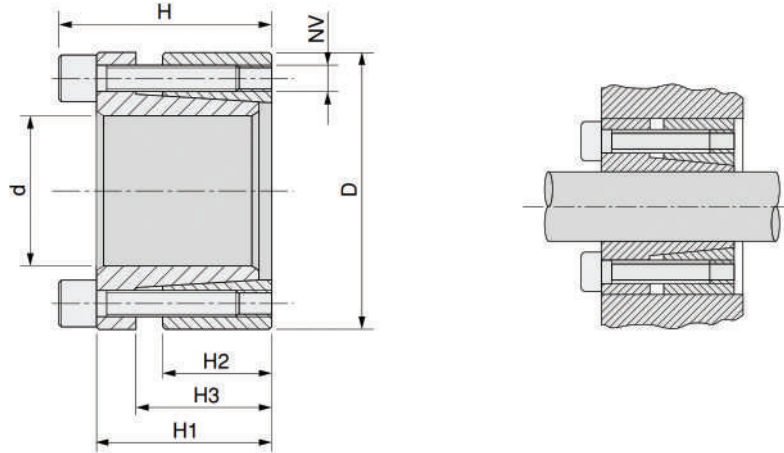

DLK132 SECTION

Part No.	Dimensions						Tightening			Loosening		Performances		Surface Pressure	
	d	D	H	H1	H2	H3	NV	Tv (Nm)	No. of screws	NV	No. of screws	Mt (mm)	Ta (KN)	Pa (N/mm ²)	Pm (N/mm ²)
DLK132-019	19	47	34	28	17	22	M6x20	13	5	M6x20	3	273	29	262	106
DLK132-020	20	47	34	28	17	22	M6x20	13	5	M6x20	3	287	29	249	106
DLK132-022	22	47	34	28	17	22	M6x20	13	5	M6x20	3	316	29	227	106
DLK132-024	24	50	34	28	17	22	M6x20	13	6	M6x20	3	413	34	249	120
DLK132-025	25	50	34	28	17	22	M6x20	13	6	M6x20	3	431	34	239	120
DLK132-028	28	55	34	28	17	22	M6x20	13	6	M6x20	3	482	34	213	109
DLK132-030	30	55	34	28	17	22	M6x20	13	6	M6x20	3	517	34	199	109
DLK132-032	32	60	34	28	17	22	M6x20	13	8	M6x20	4	734	46	249	133
DLK132-035	35	60	34	28	17	22	M6x20	13	8	M6x20	4	803	46	227	133
DLK132-038	38	65	34	28	17	22	M6x20	13	8	M6x20	4	872	46	210	122
DLK132-040	40	65	34	28	17	22	M6x20	13	8	M6x20	4	918	46	199	122
DLK132-045	45	75	41	33	20	25	M8x25	32	7	M8x25	3	1674	74	244	146
DLK132-050	50	80	41	33	20	25	M8x25	32	7	M8x25	3	1860	74	219	137
DLK132-055	55	85	41	33	20	25	M8x25	32	8	M8x25	4	2340	85	228	148
DLK132-060	60	90	41	33	20	25	M8x25	32	8	M8x25	4	2553	85	209	139
DLK132-065	65	95	41	33	20	25	M8x25	32	9	M8x25	3	3110	96	217	149
DLK132-070	70	110	50	40	24	30	M10x30	65	8	M10x30	4	4838	138	243	154
DLK132-075	75	115	50	40	24	30	M10x30	65	8	M10x30	4	5184	138	226	148
DLK132-080	80	120	50	40	24	30	M10x30	65	8	M10x30	4	5530	138	212	142
DLK132-085	85	125	50	40	24	30	M10x30	65	9	M10x30	3	6610	156	225	153
DLK132-090	90	130	50	40	24	30	M10x30	65	9	M10x30	3	6998	156	212	147
DLK132-095	95	135	50	40	24	30	M10x30	65	10	M10x30	4	8208	173	223	157

DLK132 SECTION continued

Part No.	Dimensions						Tightening			Loosening		Performances		Surface Pressure	
	d	D	H	H1	H2	H3	NV	Tv (Nm)	No. of screws	NV	No. of screws	Mt (mm)	Ta (KN)	Pa (N/mm ²)	Pm (N/mm ²)
DLK132X100	100	145	56	44	26	32	M12x35	110	8	M12x35	4	9742	195	221	152
DLK132X110	110	155	56	44	26	32	M12x35	110	8	M12x35	4	10716	195	201	143
DLK132X120	120	165	56	44	26	32	M12x35	110	9	M12x35	4	13154	219	207	151
DLK132X130	130	180	64	52	34	40	M12x35	110	12	M12x35	6	18996	292	195	141
DLK132X140	140	190	68	54	34	40	M14x40	170	9	M14x40	4	20336	291	180	133
DLK132X150	150	200	68	54	34	40	M14x40	170	10	M14x40	5	24211	323	187	140

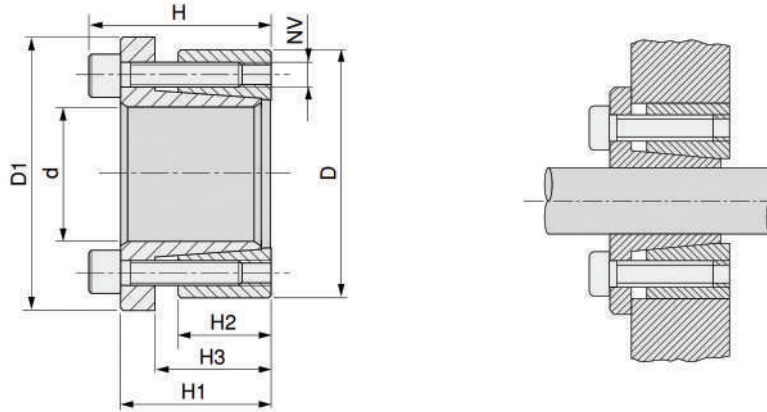

DLK133 SECTION

Part No.	Dimensions							Tightening			Loosening		Performances		Surface Pressure	
	d	D	D1	H	H1	H2	H3	NV	Tv (Nm)	No. of screws	NV	No. of screws	Mt (mm)	Ta (KN)	Pa (N/mm ²)	Pm (N/mm ²)
DLK133-019	19	47	56	34	28	17	22	M6x20	17	5	M6x20	3	243	26	234	94
DLK133-020	20	47	56	34	28	17	22	M6x20	17	5	M6x20	3	256	26	222	94
DLK133-022	22	47	56	34	28	17	22	M6x20	17	5	M6x20	3	282	26	202	94
DLK133-024	24	50	59	34	28	17	22	M6x20	17	6	M6x20	3	368	31	222	106
DLK133-025	25	50	59	34	28	17	22	M6x20	17	6	M6x20	3	383	31	213	106
DLK133-028	28	55	64	34	28	17	22	M6x20	17	6	M6x20	3	429	31	190	97
DLK133-030	30	55	64	34	28	17	22	M6x20	17	6	M6x20	3	460	31	177	97
DLK133-032	32	60	69	34	28	17	22	M6x20	17	8	M6x20	4	655	41	222	118
DLK133-035	35	60	69	34	28	17	22	M6x20	17	8	M6x20	4	716	41	203	118
DLK133-038	38	65	74	34	28	17	22	M6x20	17	8	M6x20	4	778	41	187	109
DLK133-040	40	65	74	34	28	17	22	M6x20	17	8	M6x20	4	819	41	178	109
DLK133-045	45	75	84	41	33	20	25	M8x25	41	7	M8x25	3	1458	65	212	127
DLK133-050	50	80	89	41	33	20	25	M8x25	41	7	M8x25	3	1620	65	191	119
DLK133-055	55	85	94	41	33	20	25	M8x25	41	8	M8x25	4	2037	74	199	129
DLK133-060	60	90	99	41	33	20	25	M8x25	41	8	M8x25	4	2223	74	182	121
DLK133-065	65	95	104	41	33	20	25	M8x25	41	9	M8x25	3	2710	83	189	129
DLK133-070	70	110	119	50	40	24	30	M10x30	83	8	M10x30	4	4203	120	211	134
DLK133-075	75	115	124	50	40	24	30	M10x30	83	8	M10x30	4	4754	120	197	128
DLK133-080	80	120	129	50	40	24	30	M10x30	83	8	M10x30	4	4804	120	184	123
DLK133-085	85	125	134	50	40	24	30	M10x30	83	9	M10x30	3	5742	135	195	133
DLK133-090	90	130	139	50	40	24	30	M10x30	83	9	M10x30	3	6080	135	184	128
DLK133-095	95	135	144	50	40	24	30	M10x30	83	10	M10x30	4	7131	150	194	137

DLK133 SECTION continued

Part No.	Dimensions							Tightening			Loosening		Performances		Surface Pressure	
	d	D	D1	H	H1	H2	H3	NV	Tv (Nm)	No. of screws	NV	No. of screws	Mt (mm)	Ta (KN)	Pa (N/mm ²)	Pm (N/mm ²)
DLK133X100	100	145	154	56	44	26	32	M12x35	145	8	M12x35	4	8732	175	198	137
DLK133X110	110	155	164	56	44	26	32	M12x35	145	8	M12x35	4	9605	175	180	128
DLK133X120	120	165	174	56	44	26	32	M12x35	145	9	M12x35	4	11787	196	186	135
DLK133X130	130	180	189	64	52	34	40	M12x35	145	12	M12x35	6	17024	262	175	126
DLK133X140	140	190	199	68	54	34	40	M14x40	230	9	M14x40	4	18703	267	166	122
DLK133X150	150	200	209	68	54	54	40	M14x40	230	10	M14x40	5	22259	297	172	129

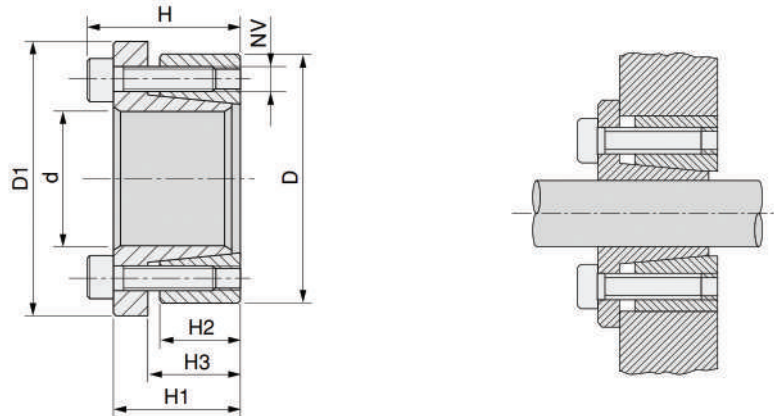

DLK134 SECTION

Part No.	Dimensions							Tightening			Loosening		Performances		Surface Pressure	
	d	D	D1	H	H1	H2	H3	NV	Tv (Nm)	No. of screws	NV	No. of screws	Mt (mm)	Ta (KN)	Pa (N/mm ²)	Pm (N/mm ²)
DLK134-114	14	55	62	39	31	17	22	M8x25	37	4	M8x25	2	234	33	415	106
DLK134-116	16	55	62	39	31	17	22	M8x25	37	4	M8x25	2	268	33	363	106
DLK134-118	18	55	62	39	31	17	22	M8x25	41	4	M8x25	2	333	37	357	117
DLK134-119	19	55	62	39	31	17	22	M8x25	41	4	M8x25	2	352	37	338	117
DLK134-120	20	55	62	39	31	17	22	M8x25	41	4	M8x25	2	370	37	321	117
DLK134-122	22	55	62	39	31	17	22	M8x25	41	4	M8x25	2	407	37	292	117
DLK134-124	24	55	62	39	31	17	22	M8x25	41	4	M8x25	2	445	37	268	117
DLK134-125	25	55	62	39	31	17	22	M8x25	41	4	M8x25	2	463	37	257	117
DLK134-128	28	55	62	39	31	17	22	M8x25	41	4	M8x25	2	519	37	229	117
DLK134-130	30	55	62	39	31	17	22	M8x25	41	4	M8x25	2	556	37	214	117
DLK134-224	24	65	72	39	31	17	22	M8x25	41	5	M8x25	3	556	46	335	124
DLK134-225	25	65	72	39	31	17	22	M8x25	41	5	M8x25	3	579	46	321	124
DLK134-228	28	65	72	39	31	17	22	M8x25	41	5	M8x25	3	649	46	287	124
DLK134-230	30	65	72	39	31	17	22	M8x25	41	5	M8x25	3	695	46	268	124
DLK134-232	32	65	72	39	31	17	22	M8x25	41	5	M8x25	3	741	46	251	124
DLK134-233	33	65	72	39	31	17	22	M8x25	41	5	M8x25	3	764	46	242	124
DLK134-235	35	65	72	39	31	17	22	M8x25	41	5	M8x25	3	811	46	230	124
DLK134-238	38	65	72	39	31	17	22	M8x25	41	5	M8x25	3	917	46	211	124
DLK134-240	40	65	72	39	31	17	22	M8x25	41	5	M8x25	3	966	46	201	124
DLK134-330	30	80	87	41	33	20	25	M8x25	41	7	M8x25	3	972	65	318	119
DLK134-332	32	80	87	41	33	20	25	M8x25	41	7	M8x25	3	1037	65	299	119
DLK134-333	33	80	87	41	33	20	25	M8x25	41	7	M8x25	3	1069	65	289	119
DLK134-335	35	80	87	41	33	20	25	M8x25	41	7	M8x25	3	1134	65	273	119

DLK134 SECTION continued

Part No.	Dimensions							Tightening			Loosening		Performances		Surface Pressure	
	d	D	D1	H	H1	H2	H3	NV	Tv (Nm)	No. of screws	NV	No. of screws	Mt (mm)	Ta (KN)	Pa (N/mm ²)	Pm (N/mm ²)
DLK134-338	38	80	87	41	33	20	25	M8X25	41	7	M8X25	3	1231	65	251	119
DLK134-340	40	80	87	41	33	20	25	M8X25	41	7	M8X25	3	1296	65	239	119
DLK134-342	42	80	87	41	33	20	25	M8X25	41	7	M8X25	3	1361	65	227	119
DLK134-345	45	80	87	41	33	20	25	M8X25	41	7	M8X25	3	1458	65	212	119
DLK134-348	48	80	87	41	33	20	25	M8X25	41	7	M8X25	3	1555	65	199	119
DLK134-350	50	80	87	41	33	20	25	M8X25	41	7	M8X25	3	1620	65	191	116

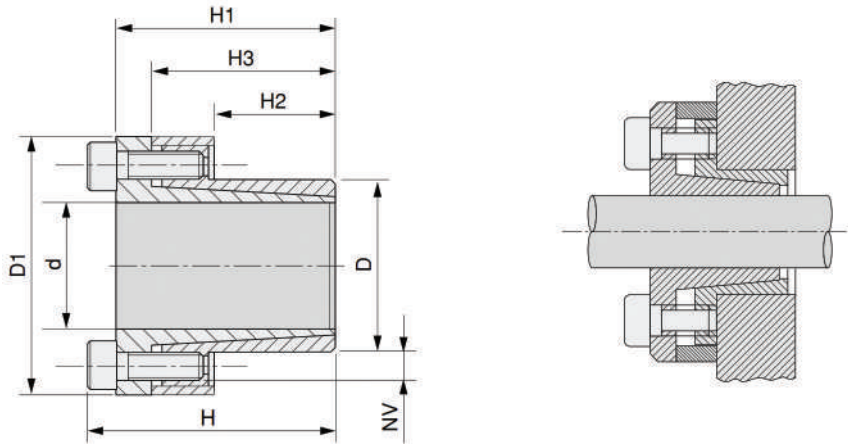

DLK110 SECTION

Part No.	Dimensions							Tightening			Loosening		Performances		Surface Pressure	
	d	D	D1	H	H1	H2	H3	NV	Tv (Nm)	No. of screws	NV	No. of screws	Mt (mm)	Ta (KN)	Pa (N/mm ²)	Pm (N/mm ²)
DLK110-008	8	15	28	28	24	12	21	M4X10	4.81	4	M4X10	3	39	10	299	159
DLK110-009	9	16	32	31	27	14	23	M4X12	5.2	4	M4X12	3	44	10	227	128
DLK110-010	10	16	32	31	27	14	23	M4X12	5.2	4	M4X12	3	49	10	205	128
DLK110-011	11	18	34	31	27	14	23	M4X12	5.2	4	M4X12	3	53	10	186	114
DLK110-012	12	18	34	31	27	14	23	M4X12	5.2	4	M4X12	3	58	10	171	114
DLK110-014	14	23	39	31	27	14	23	M4X12	5.2	4	M4X12	3	68	10	146	89
DLK110-015	15	24	45	42	36	16	29	M6X18	17	3	M6X18	2	120	16	196	123
DLK110-016	16	24	45	42	36	16	29	M6X18	17	3	M6X18	2	128	16	184	123
DLK110-018	18	26	47	44	38	18	31	M6X18	17	4	M6X18	3	191	21	194	134
DLK110-019	19	27	48	44	38	18	31	M6X18	17	4	M6X18	3	202	21	183	129
DLK110-020	20	28	49	44	38	18	31	M6X18	17	4	M6X18	3	213	21	174	124
DLK110-022	22	32	54	51	45	25	38	M6X18	17	4	M6X18	3	234	21	114	78
DLK110-024	24	34	56	51	45	25	38	M6X18	17	4	M6X18	3	255	21	105	74
DLK110-025	25	34	56	51	45	25	38	M6X18	17	4	M6X18	3	266	21	100	74
DLK110-028	28	39	61	51	45	25	38	M6X18	17	5	M6X18	3	373	27	112	81
DLK110-030	30	41	63	51	45	25	38	M6X18	17	6	M6X18	3	480	32	126	92
DLK110-032	32	43	65	56	50	30	43	M6X18	17	6	M6X18	3	511	32	98	73
DLK110-035	35	47	69	56	50	30	43	M6X18	17	8	M6X18	4	747	43	120	89
DLK110-038	38	50	72	56	50	30	43	M6X18	17	8	M6X18	4	811	43	110	84
DLK110-040	40	53	75	58	52	32	45	M6X18	17	9	M6X18	4	959	48	110	83
DLK110-042	42	55	77	58	52	32	45	M6X18	17	9	M6X18	4	1007	48	105	80
DLK110-045	45	59	85	72	64	40	56	M6X22	42	8	M6X22	4	1781	79	130	99
DLK110-048	48	62	88	72	64	40	56	M8X22	42	8	M8X22	4	1900	79	122	94

DLK110 SECTION continued

Part No.	Dimensions							Tightening			Loosening		Performances		Surface Pressure	
	d	D	D1	H	H1	H2	H3	NV	Tv (Nm)	No. of screws	NV	No. of screws	Mt (mm)	Ta (KN)	Pa (N/mm ²)	Pm (N/mm ²)
DLK110-050	50	65	92	82	74	50	66	M8X22	42	10	M8X22	5	2473	99	117	90
DLK110-055	55	71	98	82	74	50	66	M8X22	42	10	M8X22	5	2721	99	106	82
DLK110-060	60	77	104	82	74	50	66	M8X22	42	10	M8X22	5	2968	99	97	76
DLK110-065	65	84	111	82	74	50	66	M8X22	42	10	M8X22	5	3215	99	90	69
DLK110-070	70	90	122	101	91	60	80	M10X25	84	8	M10X25	4	4430	127	89	69
DLK110-075	75	95	126	101	91	60	80	M10X25	84	9	M10X25	4	5338	142	93	74
DLK110-080	80	100	131	106	96	65	85	M10X25	84	12	M10X25	5	7595	190	108	86
DLK110-085	85	106	137	106	96	65	85	M10X25	84	12	M10X25	5	8069	190	101	81
DLK110-090	90	112	143	106	96	65	85	M10X25	84	14	M10X25	6	9968	222	112	90
DLK110-095	95	120	153	106	96	65	85	M10X25	84	14	M10X25	6	10522	222	106	84
DLK110-100	100	125	162	114	102	65	89	M12X30	145	12	M12X30	5	13651	273	124	99
DLK110-110	110	140	177	119	107	70	94	M12X30	145	12	M12X30	5	15016	273	105	82
DLK110-120	120	155	195	139	127	90	114	M12X30	145	16	M12X30	7	21844	364	99	77
DLK110-130	130	165	205	139	127	90	114	M12X30	145	16	M12X30	7	23664	364	92	72
DLK110-140	140	175	215	139	127	90	114	M12X30	145	16	M12X30	7	25485	364	85	68
DLK110-150	150	185	225	139	127	90	114	M12X30	145	16	M12X30	7	27305	364	80	64

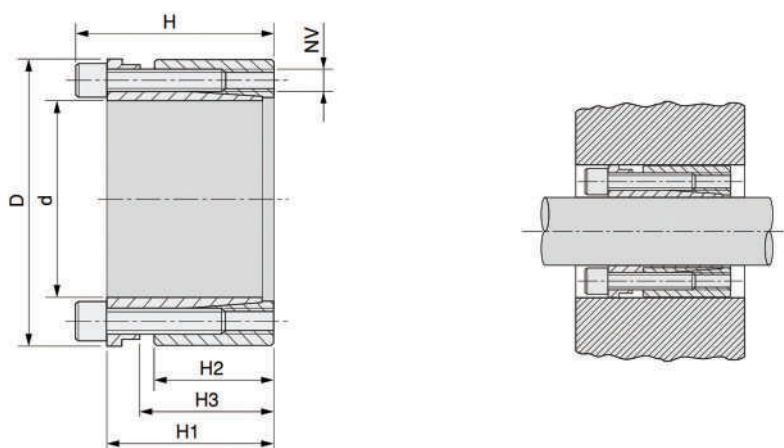

DLK130 SECTION

Part No.	Dimensions						Tightening			Loosening		Performances		Surface Pressure	
	d	D	H	H1	H2	H3	NV	Tv (Nm)	No. of screws	NV	No. of screws	Mt (mm)	Ta (KN)	Pa (N/mm ²)	Pm (N/mm ²)
DLK130-019	19	47	45	39	26	31	M6X25	17	4	M6X25	2	307	32	193	78
DLK130-020	20	47	45	39	26	31	M6X25	17	4	M6X25	2	323	32	183	78
DLK130-022	22	47	45	39	26	31	M6X25	17	4	M6X25	2	355	32	166	78
DLK130-024	24	50	45	39	26	31	M6X25	17	6	M6X25	3	382	48	229	110
DLK130-025	25	50	45	39	26	31	M6X25	17	6	M6X25	3	606	48	220	110
DLK130-028	28	55	45	39	26	31	M6X25	17	6	M6X25	3	679	48	196	100
DLK130-030	30	55	45	39	26	31	M6X25	17	6	M6X25	3	727	48	183	100
DLK130-032	32	60	45	39	26	31	M6X25	17	8	M6X25	4	1033	65	229	122
DLK130-035	35	60	45	39	26	31	M6X25	17	8	M6X25	4	1130	65	209	122
DLK130-038	38	65	45	39	26	31	M6X25	17	8	M6X25	4	1227	65	193	113
DLK130-040	40	65	45	39	26	31	M6X25	17	8	M6X25	4	1292	65	183	113
DLK130-042	42	75	55	47	30	36	M8X30	41	6	M8X30	3	1835	87	204	115
DLK130-045	45	75	55	47	30	36	M8X30	41	6	M8X30	3	1966	87	191	115

DLK130 SECTION continued

Part No.	Dimensions						Tightening			Loosening		Performances		Surface Pressure	
	d	D	H	H1	H2	H3	NV	Tv (Nm)	No. of screws	NV	No. of screws	Mt (mm)	Ta (KN)	Pa (N/mm ²)	Pm (N/mm ²)
DLK130-048	48	80	55	47	30	36	M8X30	41	6	M8X30	3	2097	87	179	107
DLK130-050	50	80	55	47	30	36	M8X30	41	6	M8X30	3	2184	87	172	107
DLK130-055	55	85	55	47	30	36	M8X30	41	8	M8X30	4	3202	116	208	135
DLK130-060	60	90	55	47	30	36	M8X30	41	8	M8X30	4	3493	116	191	127
DLK130-065	65	95	55	47	30	36	M8X30	41	8	M8X30	4	3784	116	176	120
DLK130-070	70	110	67	57	40	46	M10X35	83	8	M10X35	4	6607	189	199	127
DLK130-075	75	115	72	62	40	46	M10X35	83	8	M10X35	4	7079	189	186	121
DLK130-080	80	120	72	62	40	46	M10X35	83	8	M10X35	4	7551	189	174	116
DLK130-085	85	125	72	62	40	46	M10X35	83	10	M10X35	4	10029	236	205	139
DLK130-090	90	130	72	62	40	46	M10X35	83	10	M10X35	4	10619	236	193	134
DLK130-095	95	135	72	62	40	46	M10X35	83	10	M10X35	4	11209	236	183	129
DLK130-100	100	145	89	77	46	52	M12X45	145	8	M12X45	4	13738	275	176	121
DLK130-110	110	155	89	77	46	52	M12X45	145	8	M12X45	4	15111	278	160	114
DLK130-120	120	165	89	77	46	52	M12X45	145	10	M12X45	4	20606	343	183	133
DLK130-130	130	180	89	77	46	52	M12X45	145	12	M12X45	4	26788	412	203	147
DLK130-140	140	190	98	84	51	59	M12X45	230	8	M12X45	4	26142	373	154	114
DLK130-150	150	200	98	84	51	59	M12X45	230	10	M12X45	5	35016	467	180	135

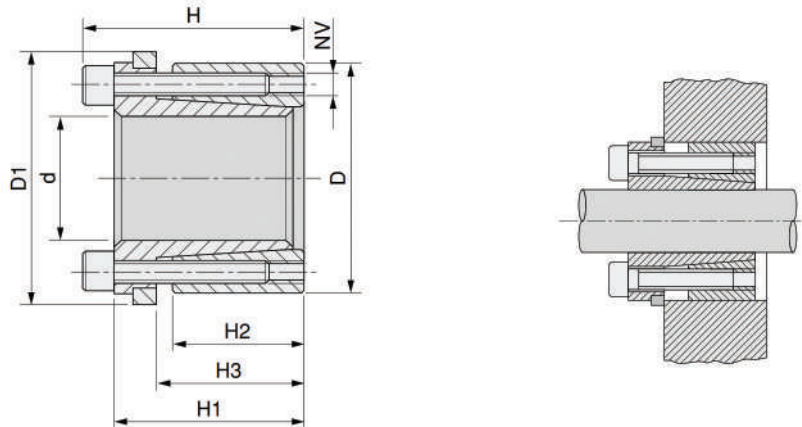

DLK131 SECTION

Part No.	Dimensions							Tightening			Loosening		Performances		Surface Pressure	
	d	D	D1	H	H1	H2	H3	NV	Tv (Nm)	No. of screws	NV	No. of screws	Mt (mm)	Ta (KN)	Pa (N/mm ²)	Pm (N/mm ²)
DLK131-019	19	47	53	45	39	26	31	M6X20	17	4	M6X20	2	202	21	127	51
DLK131-020	20	47	53	45	39	26	31	M6X20	17	4	M6X20	2	213	21	121	51
DLK131-022	22	47	53	45	39	26	31	M6X20	17	4	M6X20	2	234	21	110	51
DLK131-024	24	50	56	45	39	26	31	M6X20	17	6	M6X20	3	384	32	151	73
DLK131-025	25	50	56	45	39	26	31	M6X20	17	6	M6X20	3	400	32	145	73
DLK131-028	28	55	61	45	39	26	31	M6X20	17	6	M6X20	3	448	32	129	66
DLK131-030	30	55	61	45	39	26	31	M6X20	17	6	M6X20	3	480	32	121	66
DLK131-032	32	60	66	45	39	26	31	M6X20	17	8	M6X20	4	683	43	151	81
DLK131-035	35	60	66	45	39	26	31	M6X20	17	8	M6X20	4	747	43	138	81
DLK131-038	38	65	71	45	39	26	31	M6X20	17	8	M6X20	4	811	43	127	74
DLK131-040	40	65	71	45	39	26	31	M6X20	17	8	M6X20	4	853	43	121	74
DLK131-042	42	75	81	55	47	30	36	M8X30	41	6	M8X30	3	1216	58	135	76
DLK131-045	45	75	81	55	47	30	36	M8X30	41	6	M8X30	3	1302	58	126	76

DLK131 SECTION continued

Part No.	Dimensions							Tightening			Loosening		Performances		Surface Pressure	
	d	D	D1	H	H1	H2	H3	NV	Tv (Nm)	No. of screws	NV	No. of screws	Mt (mm)	Ta (KN)	Pa (N/mm ²)	Pm (N/mm ²)
DLK131-048	48	80	86	55	47	30	36	M8X30	41	6	M8X30	3	1389	58	119	71
DLK131-050	50	80	86	55	47	30	36	M8X30	41	6	M8X30	3	1447	58	114	71
DLK131-055	55	85	91	55	47	30	36	M8X30	41	8	M8X30	4	2124	77	138	89
DLK131-060	60	90	96	55	47	30	36	M8X30	41	8	M8X30	4	2317	77	127	84
DLK131-065	65	95	101	55	47	30	36	M8X30	41	8	M8X30	4	2510	77	117	80
DLK131-070	70	110	116	67	57	40	46	M10X35	83	8	M10X35	4	4381	125	132	84
DLK131-075	75	115	121	72	62	40	46	M10X35	83	8	M10X35	4	4694	125	123	80
DLK131-080	80	120	126	72	62	40	46	M10X35	83	8	M10X35	4	5007	125	115	77
DLK131-085	85	125	131	72	62	40	46	M10X35	83	10	M10X35	4	6651	156	136	92
DLK131-090	90	130	136	72	62	40	46	M10X35	83	10	M10X35	4	7042	156	128	89
DLK131-095	95	135	141	72	62	40	46	M10X35	83	10	M10X35	4	7433	156	121	85
DLK131-100	100	145	151	89	77	46	52	M12X45	145	8	M12X45	4	9104	182	117	81
DLK131-110	110	155	161	89	77	46	52	M12X45	145	8	M12X45	4	10015	182	106	75
DLK131-120	120	165	171	89	77	46	52	M12X45	145	10	M12X45	4	13653	228	122	88
DLK131-130	130	180	186	89	77	46	52	M12X45	145	12	M12X45	4	17757	273	135	97
DLK131-140	140	190	196	98	84	51	59	M14X45	230	8	M14X45	4	17328	248	102	75
DLK131-150	150	200	206	98	84	51	59	M14X45	230	10	M14X45	5	23207	309	119	89

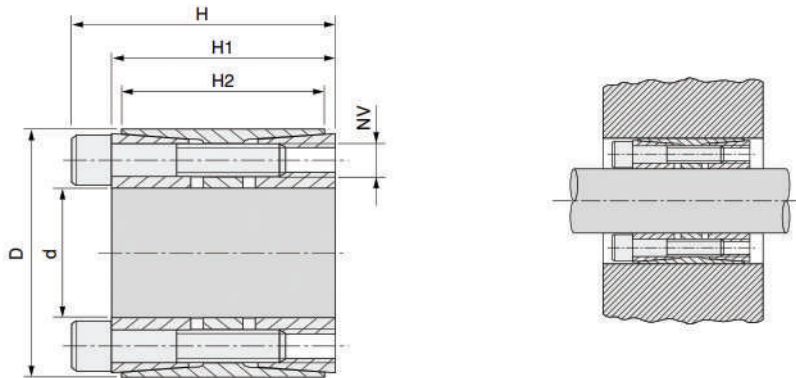

DLK450 SECTION

Part No.	Dimensions					Tightening			Loosening		Performances		Surface Pressure	
	d	D	H	H1	H2	NV	Tv (Nm)	No. of screws	NV	No. of screws	Mt (mm)	Ta (KN)	Pa (N/mm ²)	Pm (N/mm ²)
DLK450-025	25	55	46	40	32	M6X35	17	6	M6X35	3	799	64	314	107
DLK450-028	28	55	46	40	32	M6X35	17	6	M6X35	3	895	64	281	107
DLK450-030	30	55	46	40	32	M6X35	17	6	M6X35	3	959	64	262	107
DLK450-035	35	60	60	54	44	M6X45	17	7	M6X45	3	1306	75	185	83
DLK450-038	38	75	62	54	44	M8X50	41	7	M8X50	3	2567	135	308	121
DLK450-040	40	75	62	54	44	M8X50	41	7	M8X50	3	2702	135	293	121
DLK450-042	42	75	62	54	44	M8X50	41	7	M8X50	3	2837	135	279	121
DLK450-045	45	75	62	54	44	M8X50	41	7	M8X50	3	3040	135	260	121
DLK450-048	48	80	72	64	56	M8X55	41	8	M8X55	4	3707	154	216	102
DLK450-050	50	80	72	64	56	M8X55	41	8	M8X55	4	3861	154	207	102
DLK450-055	55	85	72	64	56	M8X55	41	9	M8X55	4	4779	174	212	108
DLK450-060	60	90	72	64	56	M8X55	41	10	M8X55	4	5793	193	216	113
DLK450-065	65	95	72	64	56	M8X55	41	10	M8X55	4	6276	193	199	107

DLK450 SECTION continued

Part No.	Dimensions					Tightening			Loosening		Performances		Surface Pressure	
	d	D	H	H1	H2	NV	Tv (Nm)	No. of screws	NV	No. of screws	Mt (mm)	Ta (KN)	Pa (N/mm ²)	Pm (N/mm ²)
DLK450-070	70	110	88	78	70	M10X60	83	10	M10X60	4	10951	313	235	120
DLK450-075	75	115	88	78	70	M10X60	83	10	M10X60	4	11733	313	220	115
DLK450-080	80	120	88	78	70	M10X60	83	11	M10X60	4	13768	344	227	121
DLK450-085	85	125	88	78	70	M10X60	83	12	M10X60	5	15959	376	233	127
DLK450-090	90	130	88	78	70	M10X60	83	12	M10X60	5	16898	376	220	122
DLK450-095	95	135	88	78	70	M10X60	83	12	M10X60	5	17837	376	208	117
DLK450-100	100	145	112	100	90	M12X80	145	11	M12X80	4	25029	501	211	113
DLK450-110	110	155	112	100	90	M12X80	145	12	M12X80	5	30039	546	209	115
DLK450-120	120	165	112	100	90	M12X80	145	14	M12X80	6	38226	637	224	127
DLK450-130	130	180	130	116	104	M14X90	230	12	M14X90	5	48270	743	201	117
DLK450-140	140	190	130	116	104	M14X90	230	14	M14X90	7	60654	866	217	129
DLK450-150	150	200	130	116	104	M14X90	230	15	M14X90	7	69628	928	217	132
DLK450-160	160	210	130	116	104	M14X90	230	16	M14X90	7	79220	990	217	134
DLK450-170	170	225	164	148	134	M16X120	360	14	M16X120	7	100851	1186	206	116
DLK450-180	180	235	164	148	134	M16X120	360	15	M16X120	7	114414	1271	208	119
DLK450-190	190	250	164	148	134	M16X120	360	16	M16X120	7	128814	1356	210	119
DLK450-200	200	260	164	148	134	M16X120	360	16	M16X120	7	135594	1356	200	115
DLK450-220	220	285	164	148	134	M16X120	360	18	M16X120	8	167805	1526	204	118

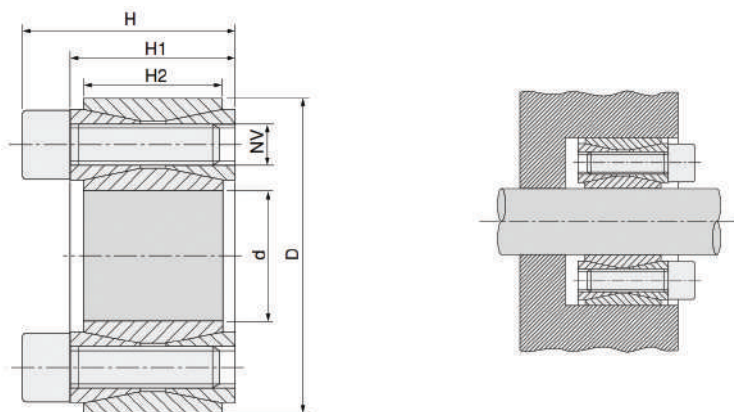

DLK200 SECTION

Part No.	Dimensions					Tightening			Loosening		Performances		Surface Pressure	
	d	D	H	H1	H2	NV	Tv (Nm)	No. of screws	NV	No. of screws	Mt (mm)	Ta (KN)	Pa (N/mm ²)	Pm (N/mm ²)
DLK200-019	19	47	26	20	17	M6X18	14.9	8	M8	2	298	31	286	116
DLK200-020	20	47	26	20	17	M6X18	14.9	8	M8	2	313	31	272	116
DLK200-022	22	47	26	20	17	M6X18	14.9	8	M8	2	345	31	247	116
DLK200-024	24	50	26	20	17	M6X18	14.9	9	M8	3	424	35	255	123
DLK200-025	25	50	26	20	17	M6X18	14.9	9	M8	3	441	35	245	123
DLK200-028	28	55	26	20	17	M6X18	14.9	10	M8	3	549	39	243	124
DLK200-030	30	55	26	20	17	M6X18	14.9	10	M8	3	588	39	227	124
DLK200-032	32	60	26	20	17	M6X18	14.9	12	M8	4	758	47	255	136
DLK200-035	35	60	26	20	17	M6X18	14.9	12	M8	4	822	47	233	136
DLK200-038	38	65	26	20	17	M6X18	14.9	14	M8	4	1042	55	250	146
DLK200-040	40	65	26	20	17	M6X18	14.9	14	M8	4	1097	55	238	146
DLK200-042	42	75	32	24	20	M8X22	35.0	12	M10	4	1740	83	291	163
DLK200-045	45	75	32	24	20	M8X22	35.0	12	M10	4	1864	83	271	163

DLK200 SECTION continued

Part No.	Dimensions					Tightening			Loosening		Performances		Surface Pressure	
	d	D	H	H1	H2	NV	Tv (Nm)	No. of screws	NV	No. of screws	Mt (mm)	Ta (KN)	Pa (N/mm ²)	Pm (N/mm ²)
DLK200-048	48	80	32	24	20	M8X22	35.0	12	M10	4	1988	83	254	153
DLK200-050	50	80	32	24	20	M8X22	35.0	12	M10	4	2071	83	244	153
DLK200-055	55	85	32	24	20	M8X22	35.0	14	M10	4	2658	97	259	168
DLK200-060	60	90	32	24	20	M8X22	35.0	14	M10	4	2900	64	238	158
DLK200-065	65	95	32	24	20	M8X22	35.0	16	M10	4	3587	110	250	171
DLK200-070	70	110	38	28	24	M10X25	69.0	14	M12	4	5345	153	268	171
DLK200-075	75	115	38	28	24	M10X25	69.0	14	M12	4	5727	153	250	163
DLK200-080	80	120	38	28	24	M10X25	69.0	14	M12	4	6108	153	235	156
DLK200-085	85	125	38	28	24	M10X25	69.0	16	M12	4	7417	175	252	172
DLK200-090	90	130	38	28	24	M10X25	69.0	16	M12	4	7854	175	238	165
DLK200-095	95	135	38	28	24	M10X25	69.0	18	M12	4	9326	196	254	179
DLK200-100	100	145	45	33	26	M12X30	123.3	14	M14	4	11362	227	258	178
DLK200-110	110	155	45	33	26	M12X30	123.3	14	M14	4	12498	227	234	166
DLK200-120	120	165	45	33	26	M12X30	123.3	16	M14	4	15578	260	245	178
DLK200-130	130	180	50	38	34	M12X35	123.3	20	M14	4	21095	325	217	156
DLK200-140	140	190	50	38	34	M12X35	123.3	22	M14	4	24993	357	221	163
DLK200-150	150	200	50	38	34	M12X35	123.3	24	M14	4	29217	390	225	169
DLK200-160	160	210	50	38	34	M12X35	123.3	26	M14	4	33756	422	229	174
DLK200-170	170	225	58	44	38	M14X40	187.0	22	M16	4	39483	465	212	160
DLK200-180	180	235	58	44	38	M14X40	187.0	24	M16	4	45606	507	218	167
DLK200-190	190	250	66	52	46	M14X45	187.0	28	M16	4	56163	591	199	152
DLK200-200	200	260	66	52	46	M14X45	187.0	30	M16	4	63342	633	203	156

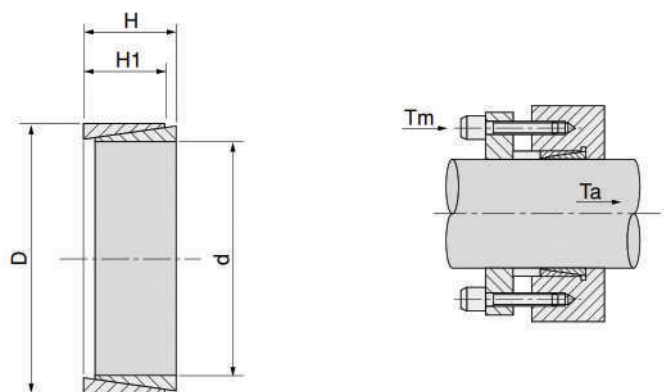

DLK300 SECTION

Part No.	Dimensions				Performances			Surface Pressure	
	d	D	H	H1	Mt (mm)	Ta (KN)	Tm (KN)	Pa (N/mm ²)	Pm (N/mm ²)
DLK300-008	8	11	4.5	3.7	4.2	1.06	5.0	100	70
DLK300-009	9	12	4.5	3.7	5.8	1.29	13.3	100	79
DLK300-010	10	13	4.5	3.7	7.6	1.53	14.4	100	86
DLK300-012	12	15	4.5	3.7	9.9	1.65	14.5	100	80
DLK300-014	14	18	6.3	5.3	18.9	2.70	23.8	100	77
DLK300-015	15	19	6.3	5.3	22.1	2.94	24.3	100	79
DLK300-016	16	20	6.3	5.3	25.4	3.18	24.5	100	81
DLK300-018	18	22	6.3	5.3	31.8	3.53	25.3	100	82
DLK300-019	19	24	6.3	5.3	35.8	3.76	29.7	100	80
DLK300-020	20	25	6.3	5.3	38.8	3.88	30.1	100	79

DLK300 SECTION continued

Part No.	Dimensions				Performances			Surface Pressure	
	d	D	H	H1	Mt (mm)	Ta (KN)	Tm (KN)	Pa (N/mm ²)	Pm (N/mm ²)
DLK300-022	22	26	6.3	5.3	47.9	4.35	28.9	100	86
DLK300-024	24	28	6.3	5.3	56.4	4.70	30.0	100	86
DLK300-025	25	30	6.3	5.3	61.7	4.94	32.4	100	84
DLK300-028	28	32	6.3	5.3	77.4	5.53	32.6	100	88
DLK300-030	30	35	6.3	5.3	88.2	5.88	35.5	100	86
DLK300-032	32	36	6.3	5.3	100.0	6.23	36.7	100	88
DLK300-035	35	40	7.0	6.0	136.0	7.76	45.7	100	88
DLK300-038	38	44	7.0	6.0	161.0	8.47	49.7	100	87
DLK300-040	40	45	8.0	6.6	195.0	9.80	58.8	100	89
DLK300-042	42	48	8.0	6.6	215.0	10.20	62.6	100	87
DLK300-045	45	52	10.0	8.6	323.0	14.30	92.2	100	87
DLK300-048	48	55	10.0	8.6	367.0	15.30	94.6	100	88
DLK300-050	50	57	10.0	8.6	397.0	15.90	96.5	100	88
DLK300-055	55	62	10.0	8.6	479.0	17.40	101.8	100	88
DLK300-060	60	68	12.0	10.4	691.0	23.00	133.4	100	88
DLK300-065	65	73	12.0	10.4	814.0	25.00	140.4	100	89
DLK300-070	70	79	14.0	12.2	1107.0	31.60	176.0	100	89
DLK300-075	75	84	14.0	12.2	1266.0	33.80	189.6	100	89
DLK300-080	80	91	17.0	15.0	1769.0	44.20	251.0	100	89
DLK300-090	90	101	17.0	15.0	2244.0	49.90	272.4	100	89
DLK300-100	100	114	21.0	18.7	3452.0	69.00	377.7	100	89
DLK300-110	110	124	21.0	18.7	4178.0	76.00	415.0	100	89
DLK300-120	120	134	21.0	18.7	4967.0	82.80	440.2	100	89
DLK300-130	130	148	28.0	25.3	7896.0	121.00	654.2	100	89
DLK300-140	140	158	28.0	25.3	9146.0	131.00	689.0	100	89
DLK300-150	150	168	28.0	25.3	10505.0	140.00	727.5	100	89

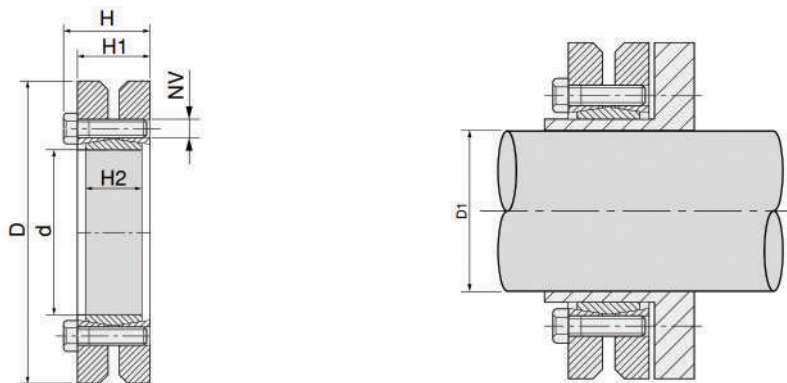

DLK603 SECTION

Part No.	Dimensions						Tightening			Performances		Surface Pressure
	d	D	D1	H	H1	H2	NV	Tv (Nm)	No. of screwa	Mt (Nm)	Ta (Kn)	Pa (N/mm ²)
DLK603-024	24	50	19	23.0	19.5	14	M5X18	4	6	216	23.0	272
			20							265	27.0	
			21							314	30.0	
DLK603-030	30	60	24	25.0	21.5	16	M5X18	4	7	372	31.0	221
			25							421	34.0	
			26							461	36.0	

DLK603 SECTION

Part No.	Dimensions						Tightening			Performances		Surface Pressure
	d	D	D1	H	H1	H2	NV	Tv (Nm)	No. of screws	Mt (Nm)	Ta (Kn)	Pa (N/mm ²)
DLK603-036	36	72	26	27.5	23.5	18	M6X20	12	5	471	36.3	292
			28							550	39.3	
			30							713	47.5	
DLK603-044	44	80	32	29.5	25.5	20	M6X20	12	7	925	57.8	301
			35							1175	67.1	
			36							1275	70.8	
DLK603-050	50	90	38	31.5	27.5	22	M6X25	12	8	1313	69.1	275
			40							1638	81.9	
			42							1925	91.7	
DLK603-055	55	100	42	34.5	30.5	23	M6X25	12	8	1450	69.0	239
			45							1900	84.4	
			48							2350	97.9	
DLK603-062	62	110	48	34.5	30.5	23	M6X25	12	10	2775	116.0	265
			50							3275	131.0	
			52							3613	139.0	
DLK603-068	68	115	50	34.5	30.5	23	M6X25	12	10	2500	100.0	242
			55							3125	114.0	
			60							3938	131.0	
DLK603-075	75	138	55	37.8	32.5	25	M8X30	30	7	3125	114.0	259
			60							4000	133.0	
			65							4938	152.0	
DLK603X80	80	145	60	37.8	32.5	25	M8X30	30	7	4000	133.0	243
			65							4875	150.0	
			70							5750	164.0	
DLK603-090	90	155	65	44.3	39.0	30	M8X35	30	10	5938	183.0	257
			70							7500	214.0	
			75							9063	242.0	
DLK603-100	100	170	70	49.3	44.0	34	M8X35	30	12	8625	246.0	245
			75							9375	250.0	
			80							11250	281.0	
DLK603-110	110	185	75	56.4	50.0	39	M10X40	59	9	9000	240.0	232
			80							11250	281.0	
			85							13500	318.0	
DLK603-125	125	215	85	60.4	54.0	42	M10X40	59	12	13750	324.0	253
			90							16250	361.0	
			95							18750	395.0	
DLK603-140	140	230	95	68.0	60.5	46	M12X45	100	10	18875	397.0	251
			100							22000	440.0	
			105							25125	479.0	
DLK603-155	155	265	105	72.0	64.5	50	M12X50	100	12	27500	524.0	250
			110							31250	568.0	
			115							35000	609.0	
DLK603-165	165	290	115	81.0	71.0	56	M16X55	250	8	38750	674.0	263
			120							43750	729.0	
			125							48750	780.0	